

LOC	DIST	REVISIONS				
A1	-	REV	DESCRIPTION	DATE	DWN	APVD
A2			DRAWING REWORKED	02MAR2000	ESKMP	-
A3			NOTE 6 1355047 WAS 116-1814	07SEP2000	ESKMP	-
A4			NEW DASH NO 1355390-6 ADDED	09JUL2003	ESKMP	SKRCH
A5			ECR-11-001151, DRAWING REWORKED	17JAN2011	GS	FT

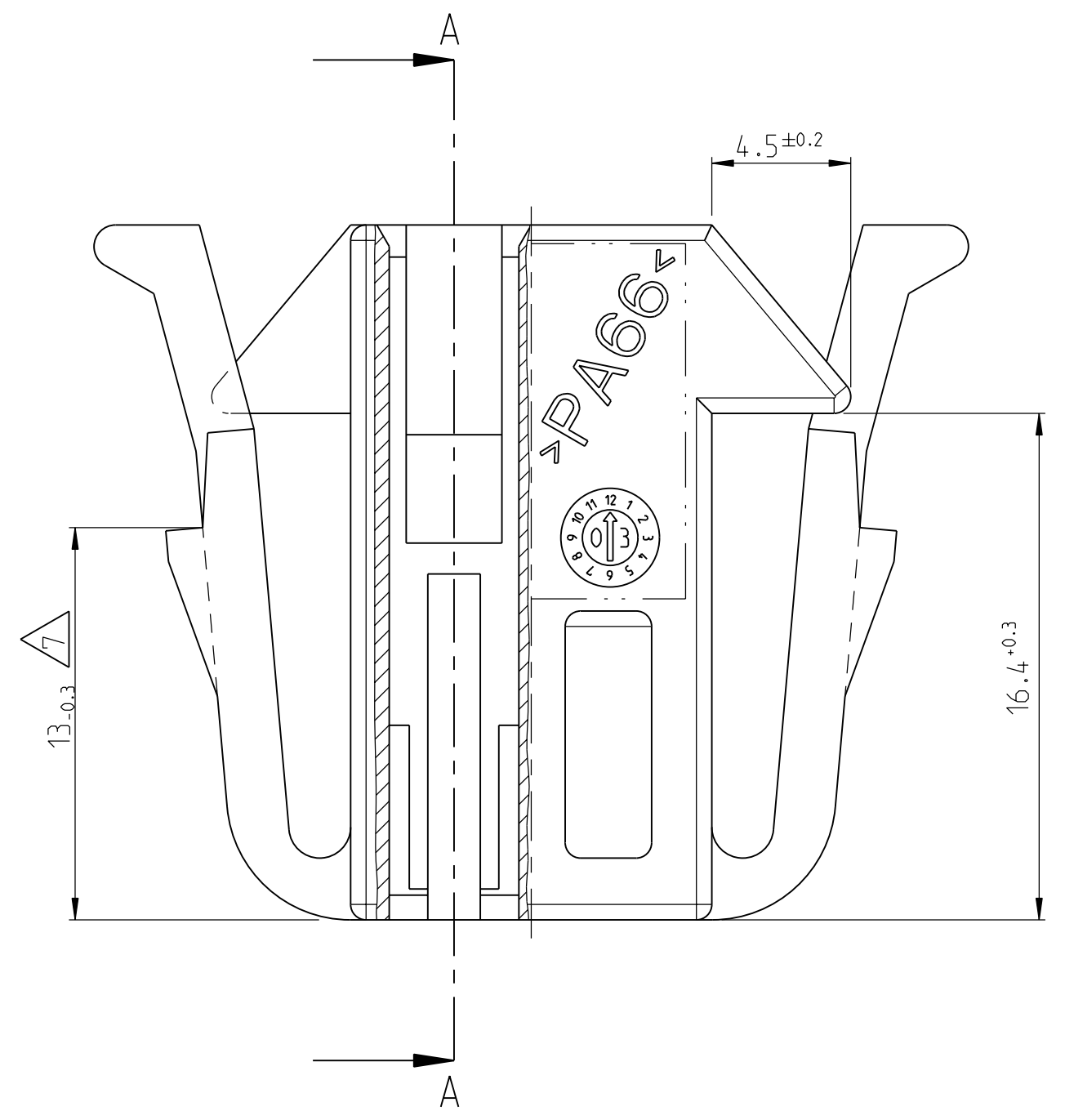

SECTION A-A
Schnitt

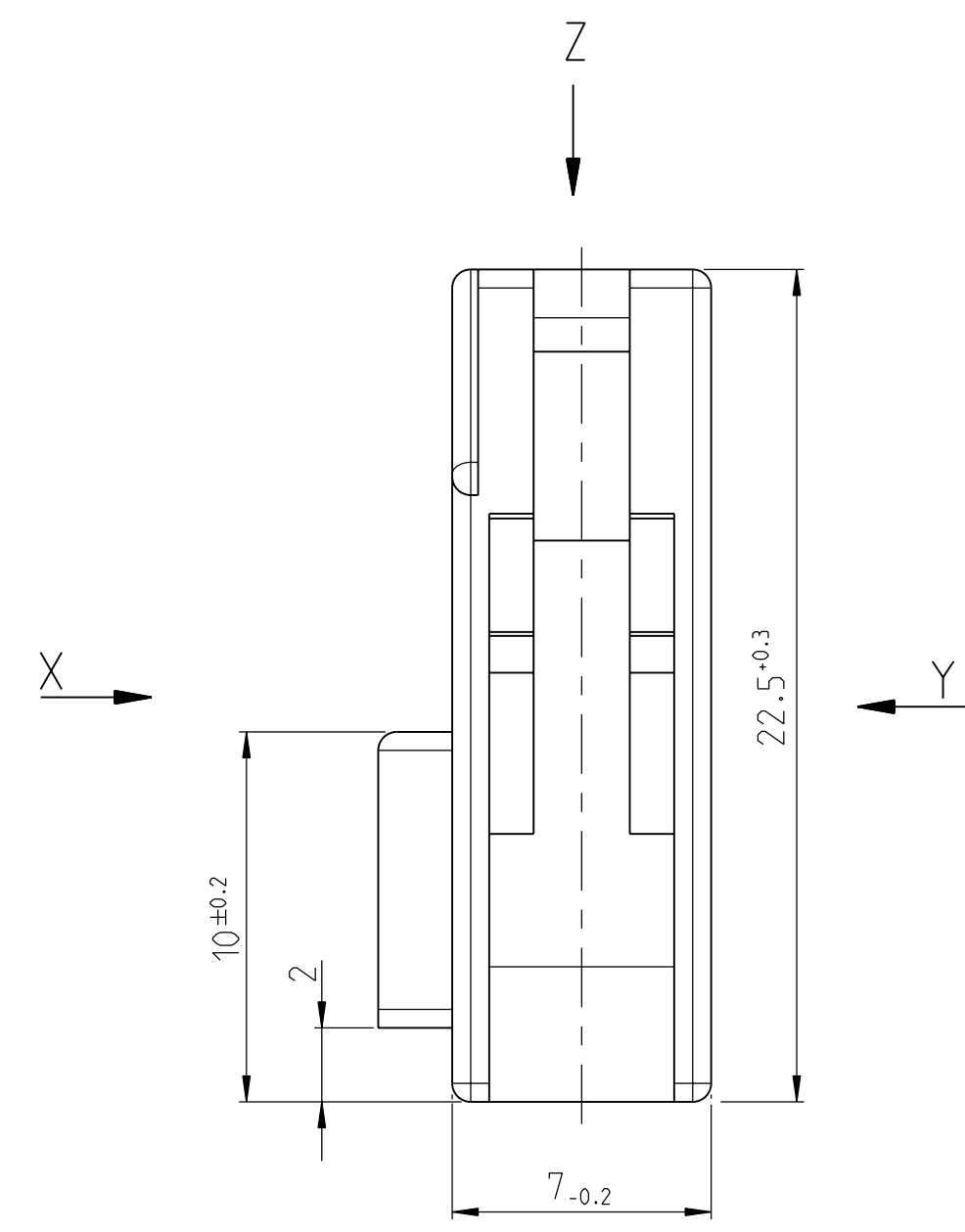
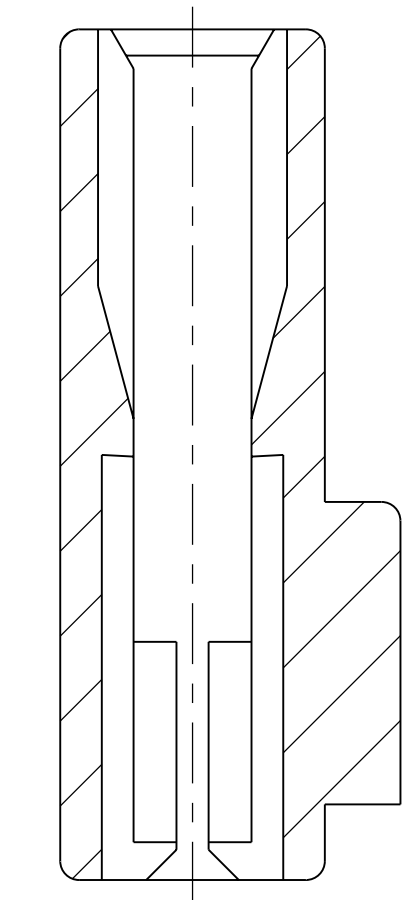

- NOTES
- 1 TE-LOGO
 - 2 TE ORDER-NO.
 - 3 MATERIAL ACC. VDA 260
 - 4 DATE OF PROCESS
 - 5 CAVITY MARKING
 - 6 USED WITH CONTACTS ACC. TO TE-PRODUCT-GROUP-DRAWING 1355047
 - 7 DIMENSION MEASURED IN 0° POSITION OF LOCKING LATCH
 - 8 COUNTER-PART 1718050-1

- BEMERKUNGEN
- 1 TE-LOGO
 - 2 BESTELLNUMMER
 - 3 MATERIALKENNZEICHNUNG NACH VDA 260
 - 4 HERSTELLDATUM
 - 5 KAMMER-NUMMIERIERUNG
 - 6 VERWENDET MIT KONTAKTEN NACH TE TABELLENZEICHNUNG 1355047
 - 7 MASSE SIND ZU MESSEN BEI 0° RASTARMSTELLUNG
 - 8 GEGENSTECKER PN 1718050-1

VIEW Z
ANSICHT

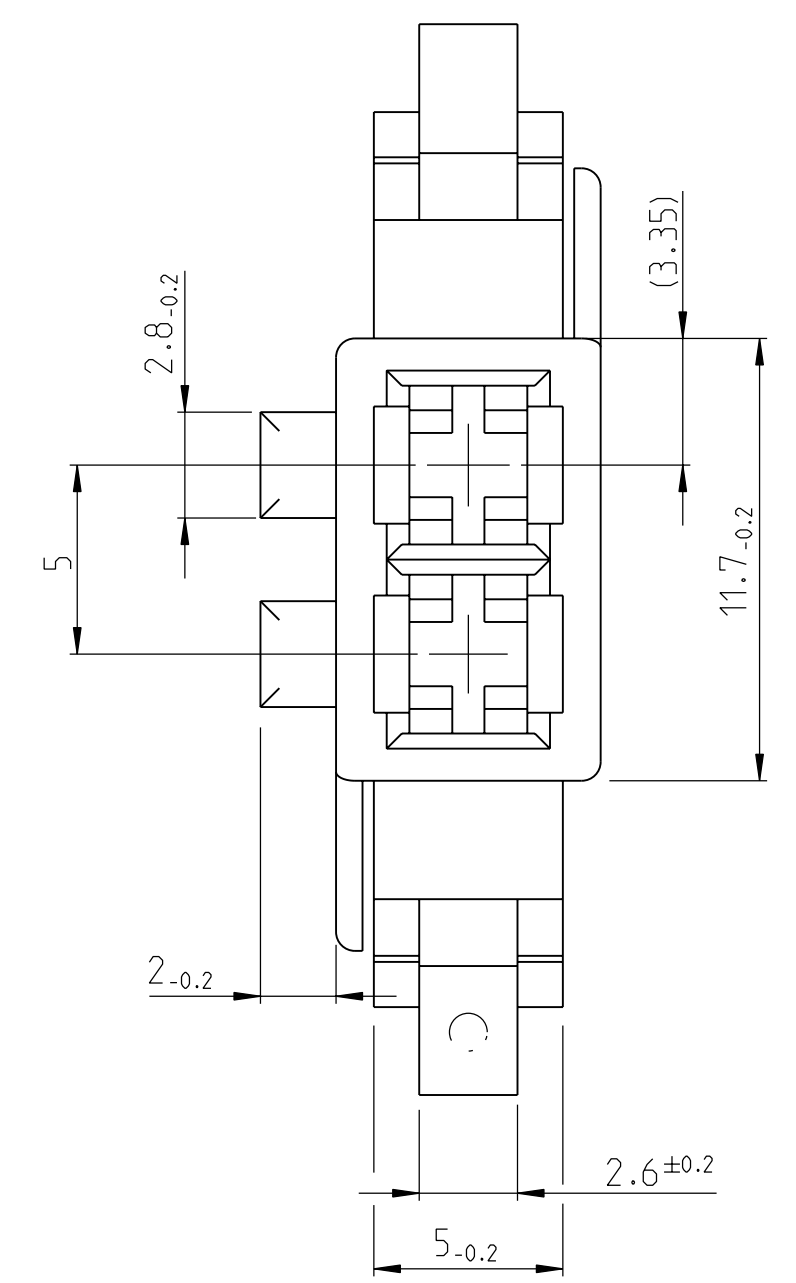

VIEW X
ANSICHT

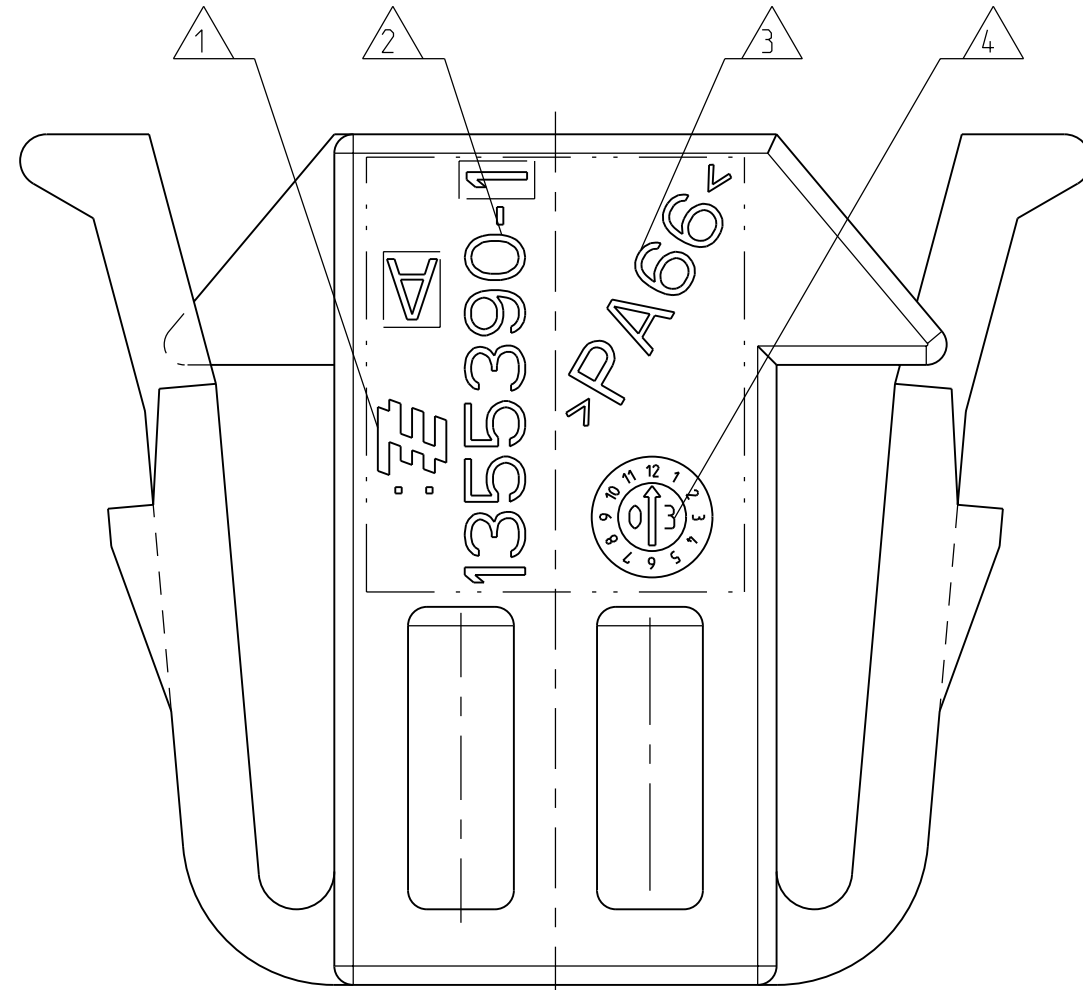

VIEW Y
ANSICHT

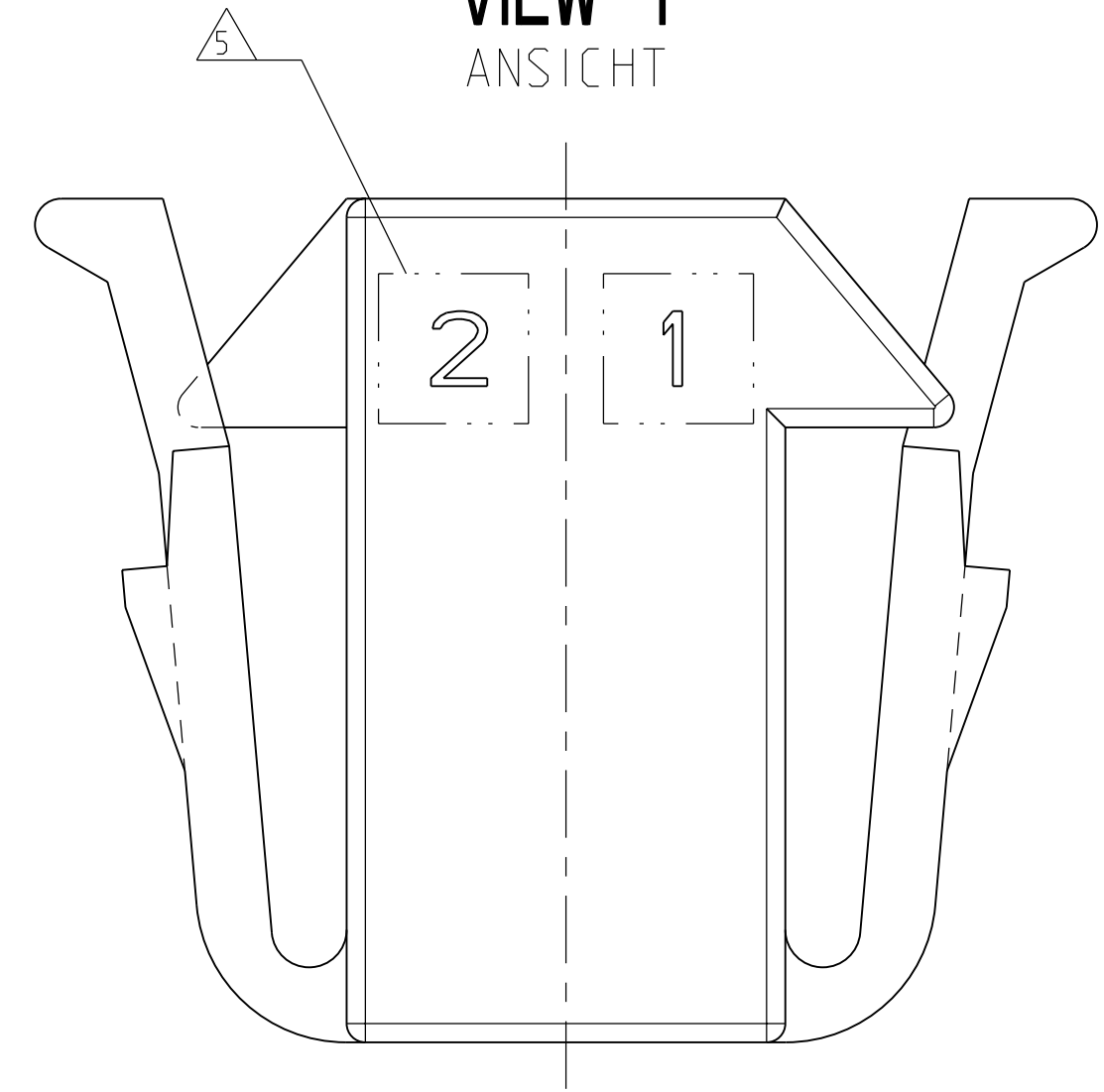

CONTACTS Kontakte	TE ORDER NO. (STRIP) TE Best.-Nr. (Band)	TE ORDER NO. (LP) TE Best.-Nr. (Einzel)	WIRE RANGE Drahtbereich	MATERIAL Material	FINISH Ausfuehrung	APPLICATION TOOLING Verarbeitungswerkzeug
6 JUNIOR POWER TIMER	965999-2	964346-2	>1.0-2.5mm ²	CuSn4	PRE TIN PLATED Vorverzinkt	HAND TOOL 539635-1 (Handzange)
	964284-2	964283-2	0.5-1.0mm ²	CuSn4	PRE TIN PLATED Vorverzinkt	DIE SET 539664-2 (Matrizensatz)
	964280-2	964279-2	0.2-0.5mm ²	CuSn4	PRE TIN PLATED Vorverzinkt	Kontakt Entriegelungs- Werkzeug 968107-1

CUSTOMER PART NO.	TE PART NO.	REV.	PCS.	MATERIAL	SURFACE/ COLOR	DESCRIPTION	ITEM NO.
-	-	-	-	-	-	-	-
-	1355390-6	A	-	PA 66	WHITE/weiss	HOUSING, 2POSN/Gehaeuse, 2pol	-
-	1355390-1	A	-	PA 66	BLACK/Schwarz	HOUSING, 2POSN/Gehaeuse, 2pol	-

DIMENSIONS:		TOLERANCES UNLESS OTHERWISE SPECIFIED:	
mm	INCH	mm	INCH
0 PLC	±0.15	0 PLC	±0.15
1 PLC	±0.15	1 PLC	±0.15
2 PLC	±0.15	2 PLC	±0.15
3 PLC	±0.15	3 PLC	±0.15
4 PLC	±0.15	4 PLC	±0.15
ANGLES	±0.5	ANGLES	±0.5
FINISH	SEE TABLE	FINISH	SEE TABLE
	siehe Tabelle		siehe Tabelle

DATE	BY	CHK	APPV	NAME	SIZE	CAGE CODE	DRAWING NO.	RESTRICTED TO
29NOV1999	R. Schäfer	L.Nix		NAME	A1	00779	©=1355390	-
09DEC1999				PRODUCT SPEC				
				APPLICATION SPEC				
				WEIGHT	1.7g			
				CUSTOMER DRAWING	/KUNDENZEICHNUNG	SCALE	5:1	SHEET 1 OF 1 REV A5

Mouser Electronics

Authorized Distributor

Click to View Pricing, Inventory, Delivery & Lifecycle Information:

[TE Connectivity:](#)
[1355390-1](#)