

WIRE SIZE	MAX INSULATION	"A" ±.012 ±0.30	"C" ±.012 ±0.30	"D" ±.005 ±0.13	"E" ±.012 ±0.30	"G" ±.005 ±0.13	"H" ±.012 ±0.30
20-24	.073/1.85	.091/2.31	.099/2.51	.030/0.76 R.	.075/1.91	.025/0.64 R.	.082/2.08
26-30	.050/1.27	.075/1.91	.083/2.10	.025/0.64 R.	.058/1.47	.020/0.51 R.	.065/1.65
18 OR 0.75mm ²	.073/1.85	.091/2.31	.099/2.51	.030/0.76 R.	.086/2.18	.029/0.74 R.	.094/2.39

MATERIAL NUMBER	PLATING	WIRE SIZE (AWG)	FORM
43030-0001	A	20-24	CHAIN
43030-0002	B	20-24	CHAIN
43030-0003	C	20-24	CHAIN
43030-0004	A	26-30	CHAIN
43030-0005	B	26-30	CHAIN
43030-0006	C	26-30	CHAIN
43030-0007	A	20-24	LOOSE
43030-0008	B	20-24	LOOSE
43030-0009	C	20-24	LOOSE
43030-0010	A	26-30	LOOSE
43030-0011	B	26-30	LOOSE
43030-0012	C	26-30	LOOSE
43030-0038	A	18 OR 0.75mm ² (SEE NOTE 10)	CHAIN
43030-0039	B	18 OR 0.75mm ² (SEE NOTE 10)	CHAIN
43030-0040	C	18 OR 0.75mm ² (SEE NOTE 10)	CHAIN

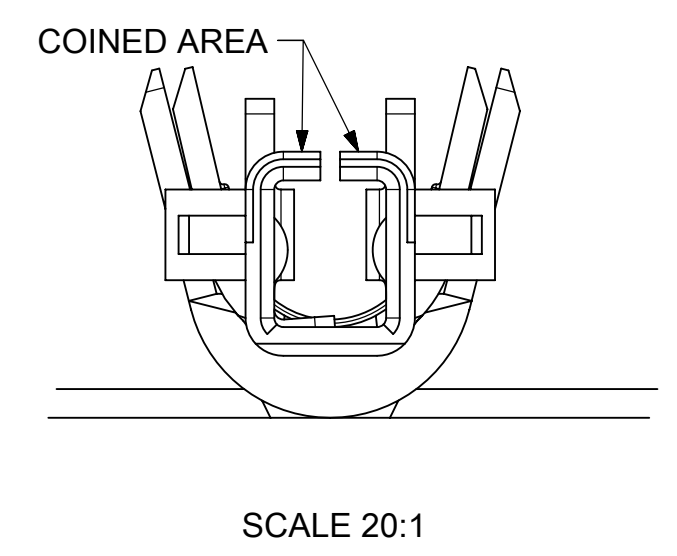
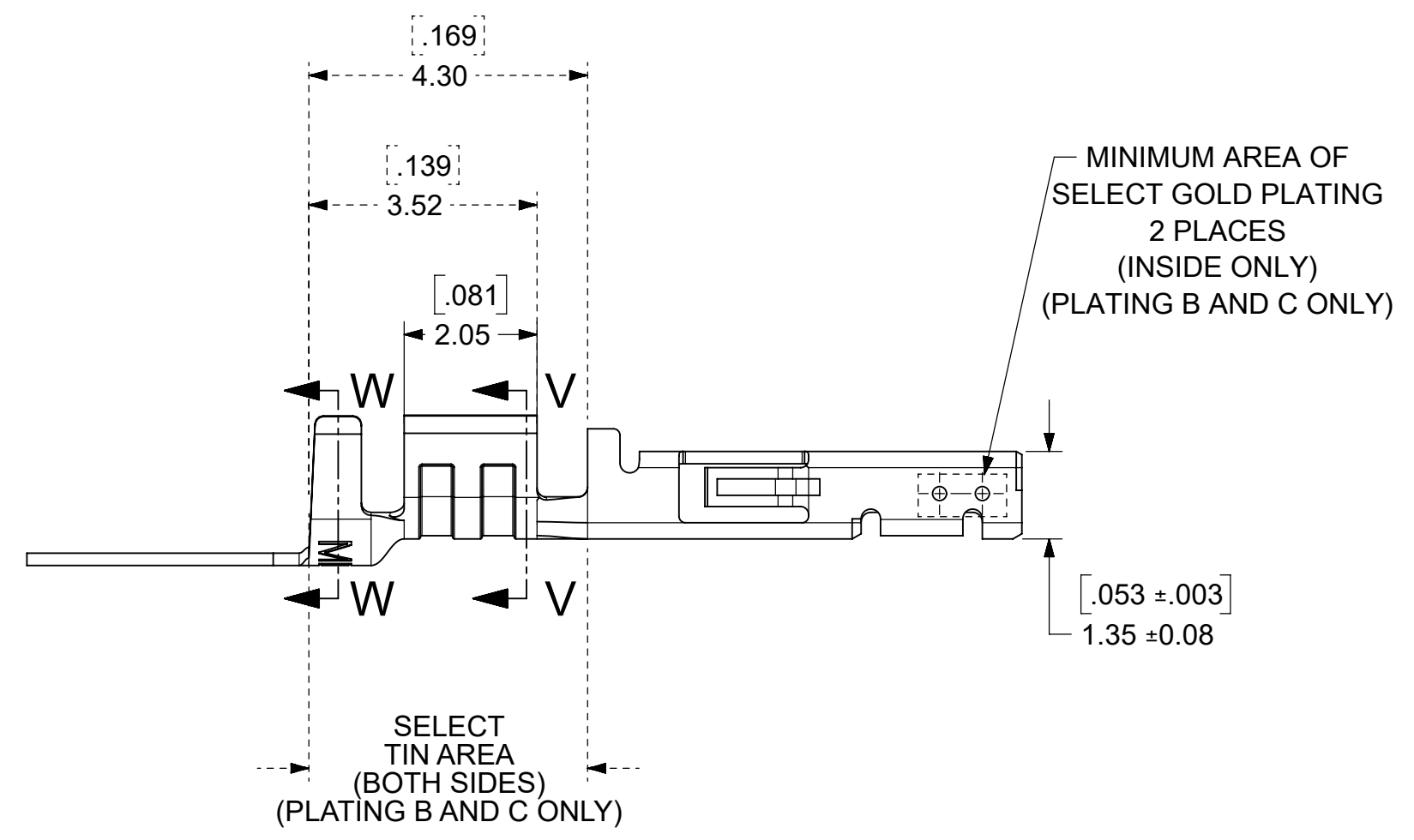
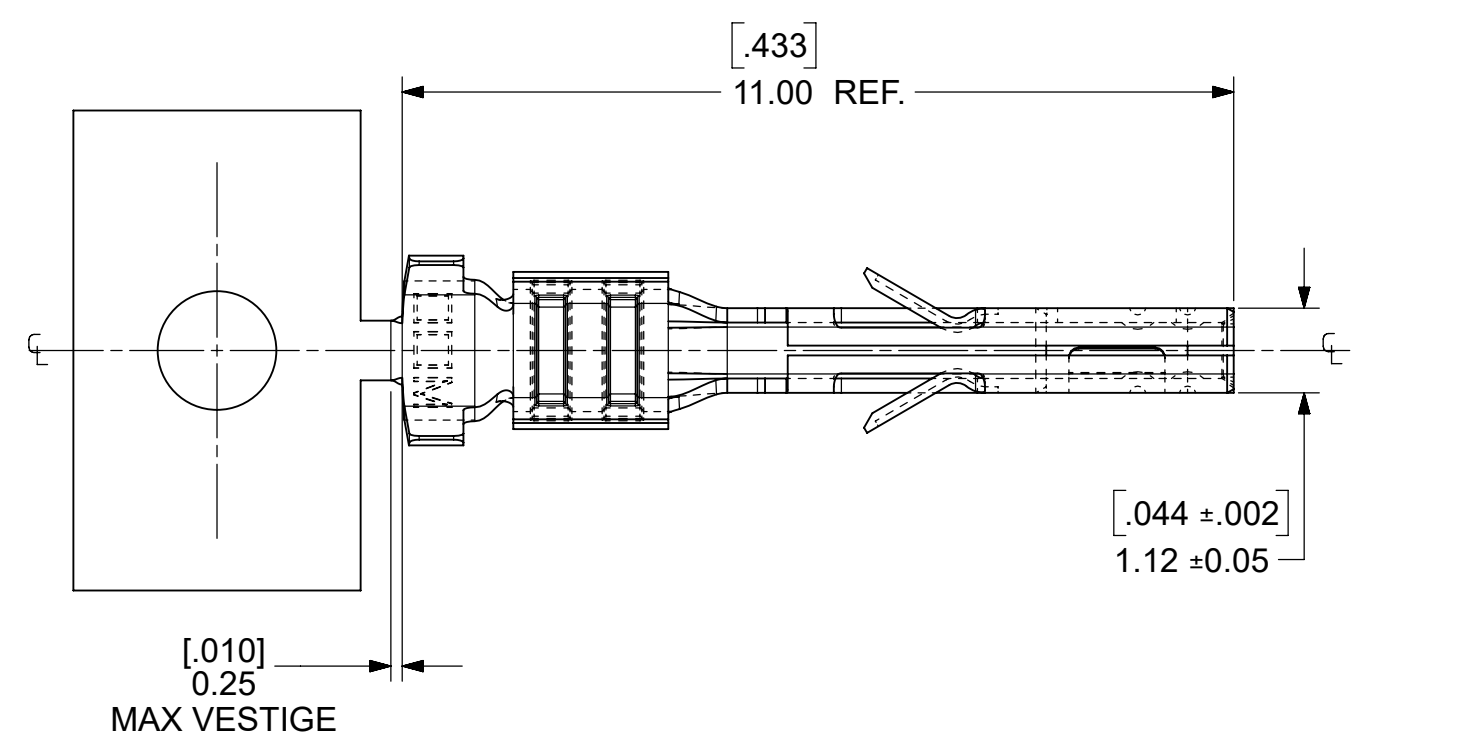
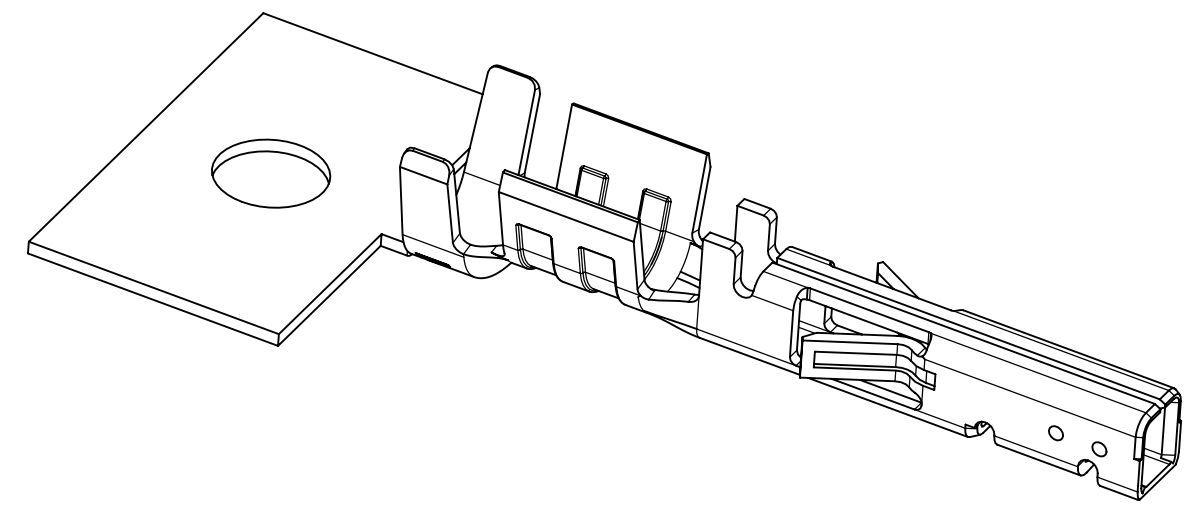
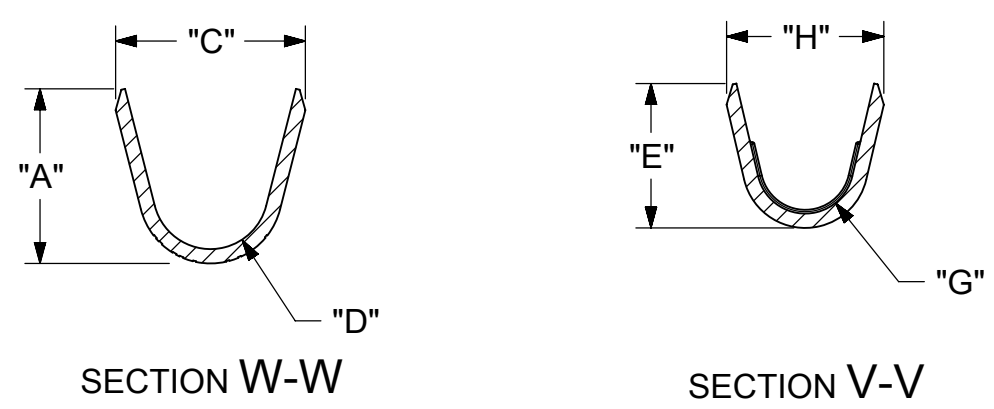

- NOTES
- MATERIAL: PHOSPHOR BRONZE ALLOY
 - TERMINAL PLATING:
 "A" - HOT TIN DIP: .000040/0.00102 MIN. OVERALL
 "B" - .000015/0.00038 MIN. SELECT GOLD
 .000100/0.00254 MIN. SELECT TIN
 ALL OVER .000050/0.00127 MIN. NICKEL OVERALL.
 "C" - .000030/0.00076 MIN. SELECT GOLD
 .000100/0.00254 MIN. SELECT TIN
 ALL OVER .000050/0.00127 MIN. NICKEL OVERALL.
 PLATING FINISHES B AND C ARE POST PLATED.
 - PRODUCT SPECIFICATION: PS-43045, PS-43650, PS-44300-001.
 - PACKAGING SPECIFICATION: PK-43030-001 (REEL), PK-43030-003 (LOOSE).
 - TERMINAL FOR USE IN MICRO-FIT RECEPTACLE SERIES 43025, 43645, 44133, AND 46623. ONLY 20-24 AWG AND 26-30 AWG TERMINALS CAN BE USED IN TPA RECEPTACLE SERIES 171850 AND 172952.
 - FOR TERMINAL ORIENTATION IN RECEPTACLE SEE DRAWINGS FOR RECEPTACLES.
 - THIS TERMINAL IS DESIGNED IN METRIC.
 - MOLEX RECOMMENDS THE USE OF MICRO-FIT TEST PLUG (SERIES 44242) WHENEVER CONTINUITY TESTING IS PERFORMED. TEST PLUGS MUST NOT BE USED TO MAKE OR BREAK UNDER LOAD. MOLEX DOES NOT RECOMMEND USING STANDARD MATING COMPONENTS (SERIES 43020, 43045, 43640, 43650, OR 43031) FOR HARNESS TESTING PURPOSES.
 - TEXT ON PART IS FOR REFERENCE ONLY. TEXT AND TEXT LOCATION MAY VARY DEPENDING ON PART NUMBER AND/OR TOOL.
 - 18 AWG PART NUMBERS ARE DESIGNED FOR 18 AWG 1061 STYLE WIRE OR A .073/1.85 MAXIMUM INSULATION OUTSIDE DIAMETER.

FUNCTIONAL SYMBOLS	THIS DRAWING CONTAINS INFORMATION THAT IS PROPRIETARY TO MOLEX ELECTRONIC TECHNOLOGIES, LLC AND SHOULD NOT BE USED WITHOUT WRITTEN PERMISSION			
	DIMENSION UNITS	SCALE	CURRENT REV DESC: CORRECT 3.52 DIMENSION	
$\frac{F}{A} = 0$	INCH/MM	10:1		
$\frac{F}{C} = 0$	GENERAL TOLERANCES (UNLESS SPECIFIED)			
$\frac{F}{P} = 0$		MM	INCH	
DIVISIONAL SYMBOLS	4 PLACES	±	±	EC NO: 730513
	3 PLACES	±	± 0.01	DRWN: RICARC13 2022/10/28
	2 PLACES	± 0.25	± 0.014	CHK'D: MKIPPER 2022/12/01
	1 PLACE	± 0.35	±	APPR: XQZHANG 2023/05/04
	0 PLACES	±	±	INITIAL REVISION:
	ANGULAR TOL	± 0.5 °	DRWN: MUELLER 2002/08/03	DOCUMENT NUMBER
	DRAFT WHERE APPLICABLE MUST REMAIN WITHIN DIMENSIONS	THIRD ANGLE PROJECTION	DRAWING	SERIES
			C-SIZE	43030
			MATERIAL NUMBER	CUSTOMER
			SEE TABLE	GENERAL MARKET
			SHEET NUMBER	1 OF 1

molex

MICRO-FIT (3.0) FEMALE CRIMP TERMINAL

PRODUCT CUSTOMER DRAWING

DOCUMENT NUMBER: SD-43030-XXXX
 DOC TYPE: PSD
 DOC PART: 001
 REVISION: N9