

LOC	DIST	REVISIONS					
		P	LTR	DESCRIPTION	DATE	DWN	APVD
1	-		AV	ET00044896	21-Oct-1996	H.Y.	-
			AV1	ET00034799	18-Nov-1999	H.Y.	-
			AV2	REDRAWN FOR CLARITY	11-NOV-2009	PKS	RRP
			AV3	180453-6 DETAILS ADDED TO P/N TABLE	15-Jun-2010	MRS	PKS

SECTION A-A

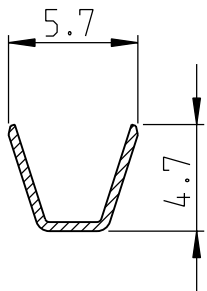

NOTES:

- 1 FORNITO IN BOBINA Ø24" CON CARTA INTERPOSTA TRA LE SPIRE DEI TERMINALI (TERMINAL REELED ON 24" STD CARTON REEL WITH INTERLEAVE PAPER STRIP)
- 2 NON DISPONIBILE DALL TE ITALIA (NOT AVAILABLE FROM TE ITALY)
- 3 REVERSE REELED FOR AMP-O-MATOR

SECTION B-B

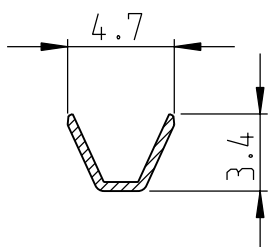

SECTION C-C

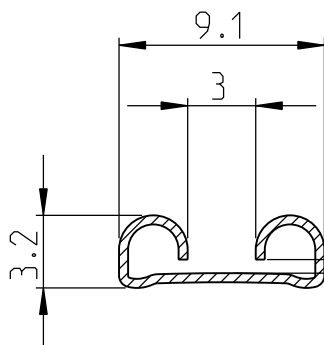

ADATTO PER LINGUETTA DA 0.8mm DI SPESSE  
(SUITABLE FOR TAB 0.8mm THK.)

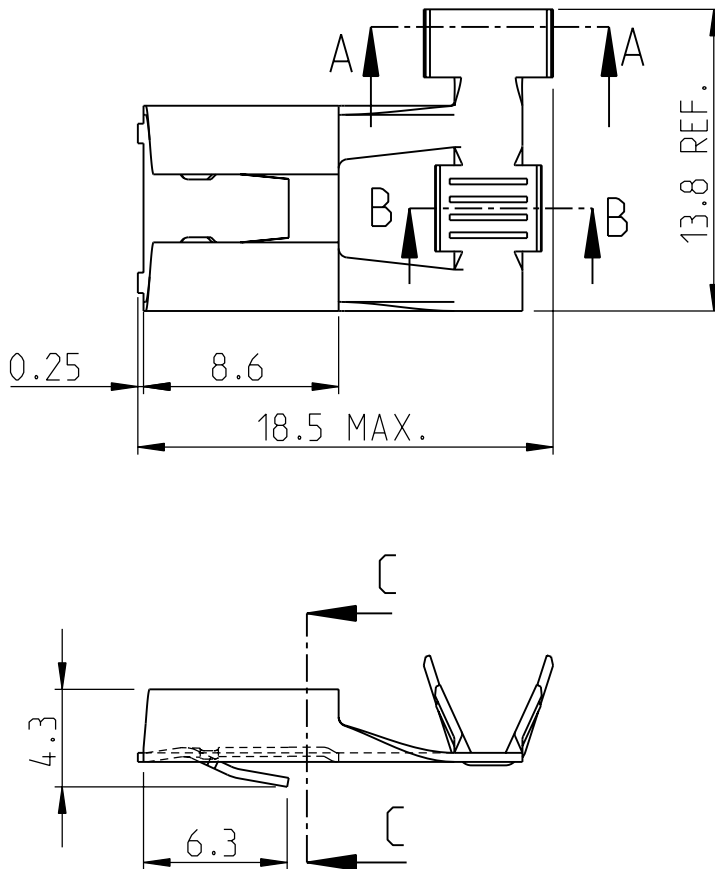

1962

RELEASED FOR PUBLICATION

BY TYCO ELECTRONICS CORPORATION. ALL INTERNATIONAL RIGHTS RESERVED.

THIS DRAWING IS UNPUBLISHED.

1	2	PHOS. BRONZE	2-180453-5	3				
TIN	1	BRASS	1-180453-2	3	TIN	BRASS	180453-2	3
TIN		PHOS. BRONZE	180453-6	3	-	BRASS	180453-1	3
SILVER		BRASS	180453-4	3	SILVER	BRASS	180373-6	
SILVER		PHOS. BRONZE	180453-3	3	TIN	PHOS. BRONZE	180373-5	
FINISH/FINITURA	MATERIAL/MATERIALE	P/N	FINISH/FINITURA	MATERIAL/MATERIALE	P/N	FINISH/FINITURA	MATERIAL/MATERIALE	P/N

DIMENSIONS:		DWN	12-10-62	MATERIAL		FINISH	
mm		A.MERLINO		SEE TABLE		SEE TABLE	
TOLERANCES UNLESS OTHERWISE SPECIFIED:		CHK	12-10-62	Tyco Electronics Tyco Electronics AMP ITALIA TORINO, ITALIA			
0 PLC ±		R.BAKKER					
1 PLC ±0.4		APVD	12-10-62	NAME			
2 PLC ±		R.BAKKER		312 SERIES FLAG FAST-IN-ON RECEPTACLE			
3 PLC ±		PRODUCT SPEC		SIZE			
4 PLC ±		APPLICATION SPEC		CAGE CODE		DRAWING NO	
ANGLES ±2°		WEIGHT		A 4 00779		C-180373	
		CUSTOMER DRAWING		SCALE		RESTRICTED TO	
				3:1		-	
				SHEET		REV	
				1 OF 1		AV3	