

THIS DRAWING IS UNPUBLISHED. RELEASED FOR PUBLICATION 20  
 © COPYRIGHT 20 BY TYCO ELECTRONICS CORPORATION. ALL RIGHTS RESERVED.

LOC	DIST	REVISIONS			
P	LTR	DESCRIPTION	DATE	DWN	APVD
AL	2	AC	REVISED BY ES00-0040-02	02APR02	J.L J.L
		AD	REVISED BY ES00-05-0095	14/DEC/05	J.L JL
		AD1	REVISED PER ECO-10-000444	09JAN10	KK AEG
		AD2	ECR-10-009742	29JUN10	RK SRE
		AD3	ADDED NEW DASH 3-160759-4	22MAR11	J.S. L.B.
		AD4	UPDATED TE CONNECTIVITY LOGO	04APR2011	J.S. L.B.

NOTES:

- 1 FOR USE ON STANDARD APPLICATOR (RIGHT-LEFT FEED)
- 2 FOR USE ON MINIATURE APPLICATOR (LEFT-RIGHT FEED)
- 3 FOR USE ON MINIATURE APPLICATOR (LEFT-RIGHT FEED) AMPOMATOR APPLICATION.
- 4 CONFIGURATION OF CARRIER-STRIP OPTIONAL
- 5 OBSOLETE PARTS: OBSOLETE CIS STREAMLINING PER D.RENAUD/D.SINISI

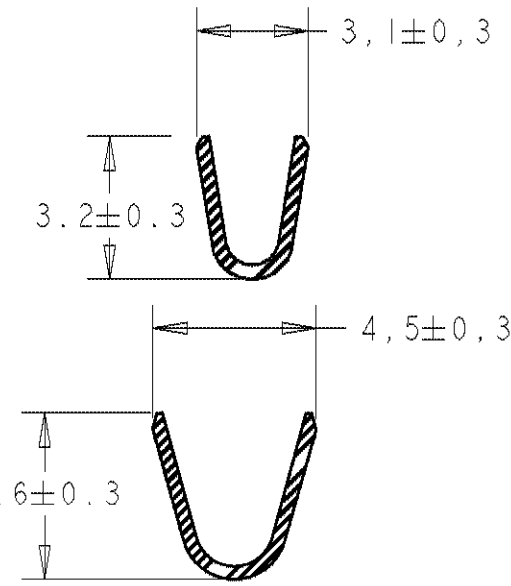
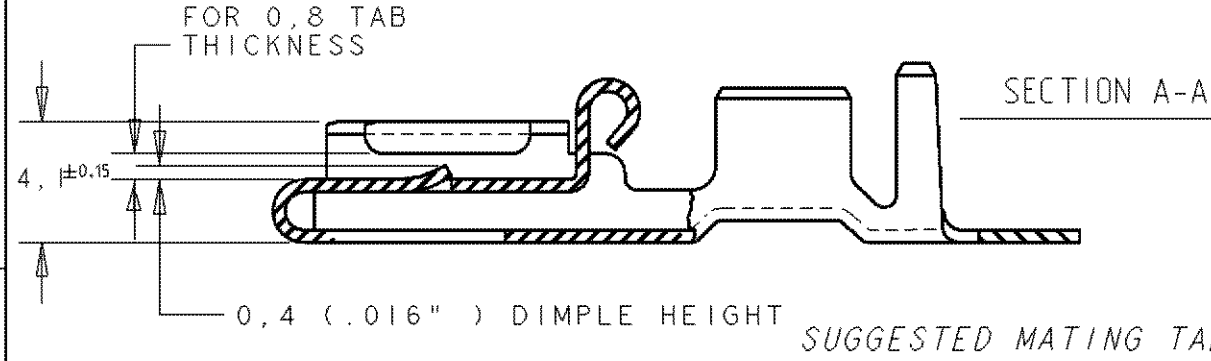
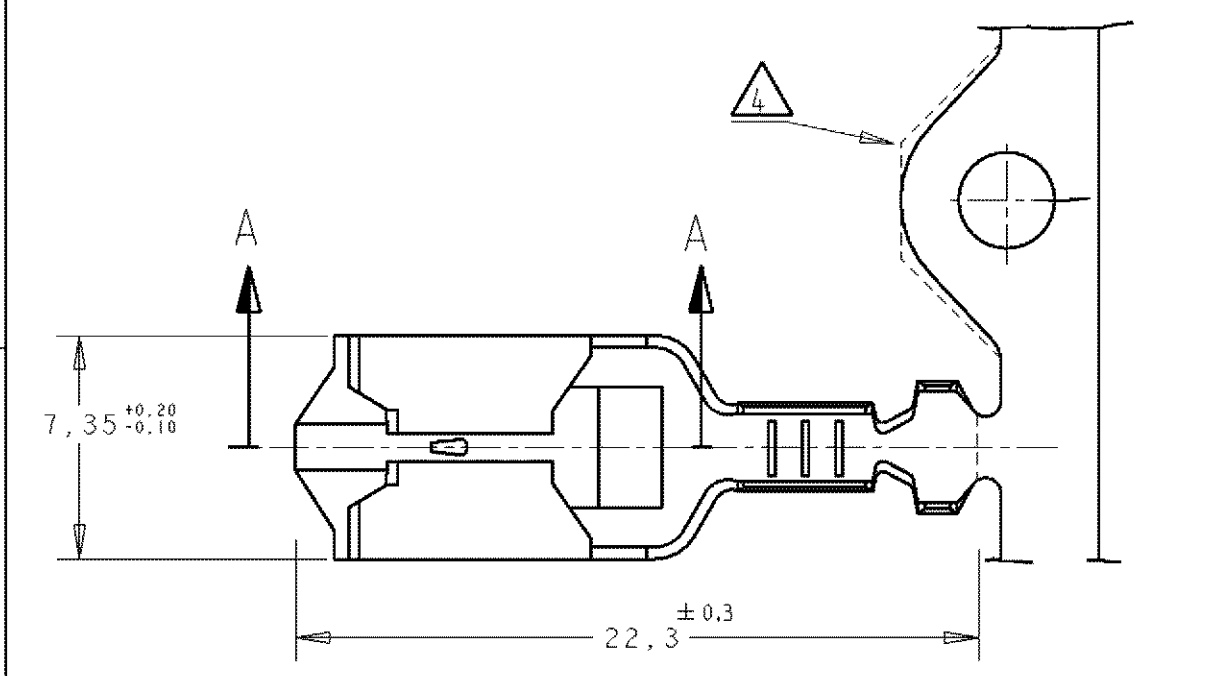

- 1- MATL. 1/2H BRASS OR NICKEL PL. STEEL.
- 2- NO BURRS PERMISSIBLE AT HOLE
- 3- MUST BE FLAT WITHIN 0.076 OVER THIS LENG.
- 4- TIN PLATING IS REQUIRED ON BRASS WHEN TERMINAL TEM. IS OVER 225°F
- 5- HOLE MUST BE SYMETRICAL ABOUT TAB  $\phi$  WITHIN 0.076

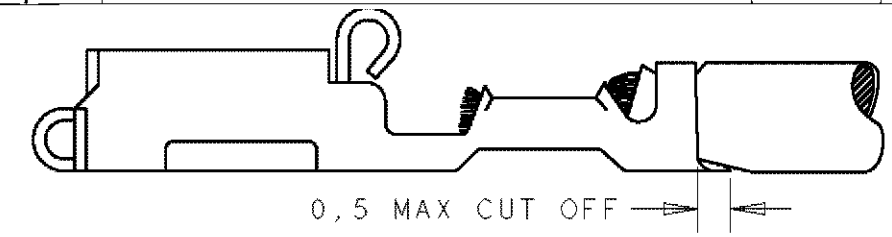
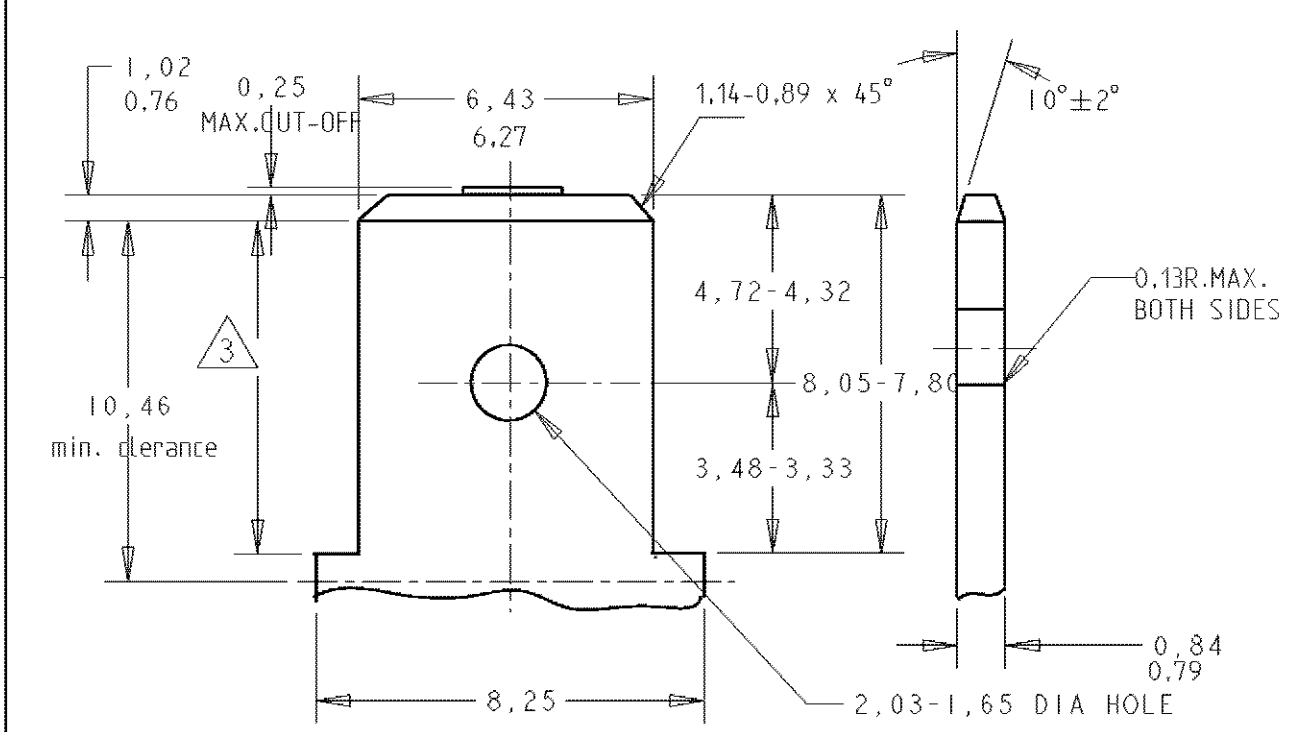

FINISH	MATERIAL	PARTNUMBER
UNPLATED & DEGREASED	NICKEL SILVER	3-160759-4
UNPLATED	NICKEL SILVER	3-160759-3
OBSOLETE UNPLATED	NICKEL SILVER	3-160759-3
TIN PLATED	PH.BRONZE	3-160759-0
UNPLATED	NICKEL SILVER	2-160759-9
OBSOLETE HOT DIP PRETIN.	PH.BRONZE	2-160759-8
SUPERSEDED BY 160759-4 TIN-LEAD	PH.BRONZE	2-160759-7
OBSOLETE SILVERPLATED	BRASS	2-160759-6
OBSOLETE UNPLATED	BRASS	2-160759-5
OBSOLETE HOT DIP PRETIN.	BRASS	2-160759-4
TIN PLATED	BRASS	2-160759-3
NICKEL PLATED	PH.BRONZE	2-160759-2
NICKEL PLATED	PH.BRONZE	2-160759-1
OBSOLETE SILVERPLATED	PH.BRONZE	2-160759-0
SILVERPLATED	PH.BRONZE	1-160759-9
HOT DIP PRETIN.	PH.BRONZE	1-160759-4
OBSOLETE HOT DIP PRETIN.	BRASS	1-160759-3
HOT DIP PRETIN.	PH.BRONZE	1-160759-2
HOT DIP PRETIN.	BRASS	1-160759-1
OBSOLETE PRETINNED	PH.BRONZE	1-160759-0
OBSOLETE TIN PLATED	PH.BRONZE	0-160759-9
OBSOLETE TIN PLATED	BRASS	0-160759-8
UNPLATED	PH.BRONZE	0-160759-7
UNPLATED	BRASS	0-160759-6
OBSOLETE PRETINNED	PH.BRONZE	0-160759-5
TIN PLATED	PH.BRONZE	0-160759-4
TIN PLATED	BRASS	0-160759-3
UNPLATED	PH.BRONZE	0-160759-2
UNPLATED	BRASS	0-160759-1

THIS DRAWING IS A CONTROLLED DOCUMENT FOR TYCO ELECTRONICS CORPORATION IT IS SUBJECT TO CHANGE AND THE CONTROLLING ENGINEERING ORGANIZATION SHOULD BE CONTACTED FOR THE LATEST REVISION.

DIMENSIONS:	TOLERANCES UNLESS OTHERWISE SPECIFIED:
mm	0 PLC ±
	1 PLC ±
	2 PLC ±0,3 GENERAL
	3 PLC ±
	4 PLC ±
	ANGLES ±
MATERIAL	FINISH
SEE TABLE	SEE TABLE

DWN	J.Z	16-11-95
CHK	A. BIJNEN	17-11-95
APVD	-	-
PRODUCT SPEC	108-3017	
APPLICATION SPEC	-	
WEIGHT	-	
CUSTOMER DRAWING		

STE  
TE Connectivity

NAME			RESTRICTED TO		
POSITIVE LOCK REC. .250 (6,35) SERIES					
SIZE	CAGE CODE	DRAWING NO			
A3	00779	C=160759			
SCALE	SHEET	OF	REV		
-			AD4		