

# ZRO CONNECTOR

## Board-to-wire/Sealed connector

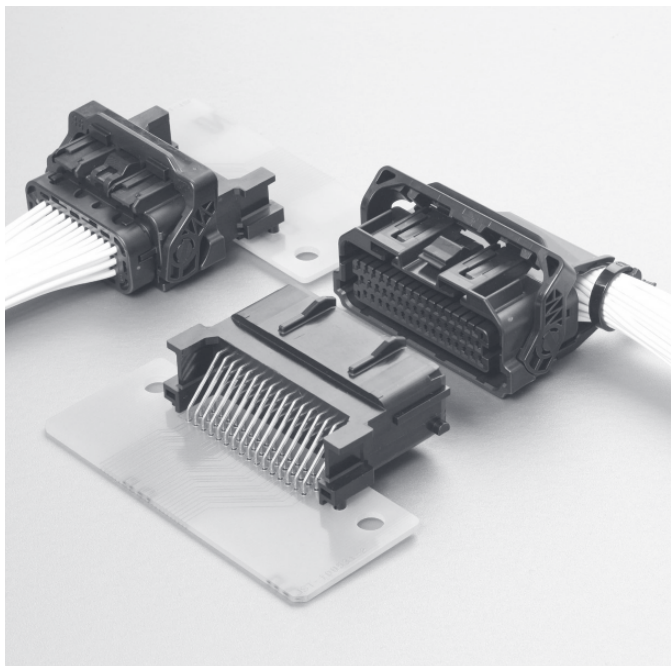

This connector is an interface connector, 48 and 36 circuits sealed and lever type.

### Features

- **Improvement of Operability**  
The lever is adopted to decrease the connector mating force. The fixing part to PC board is snap fit configuration in consideration of the workability when assembling.
- **Sealed**  
Mat seal is adopted for improving the workability of wire seal part.
- **Durability**  
Heat resistant specification corresponding to 120°C.
- **Reduced waste structure**  
Low cost and low resources are realized by abolishing use of the wire rod pin and the alignment board.
- **Variations**  
This connector is available in two kinds of keying codes. If the harness cover of an option is used, the harness can be taken out from the side.  
Circuits: Lineup of 48 and 36 circuits.

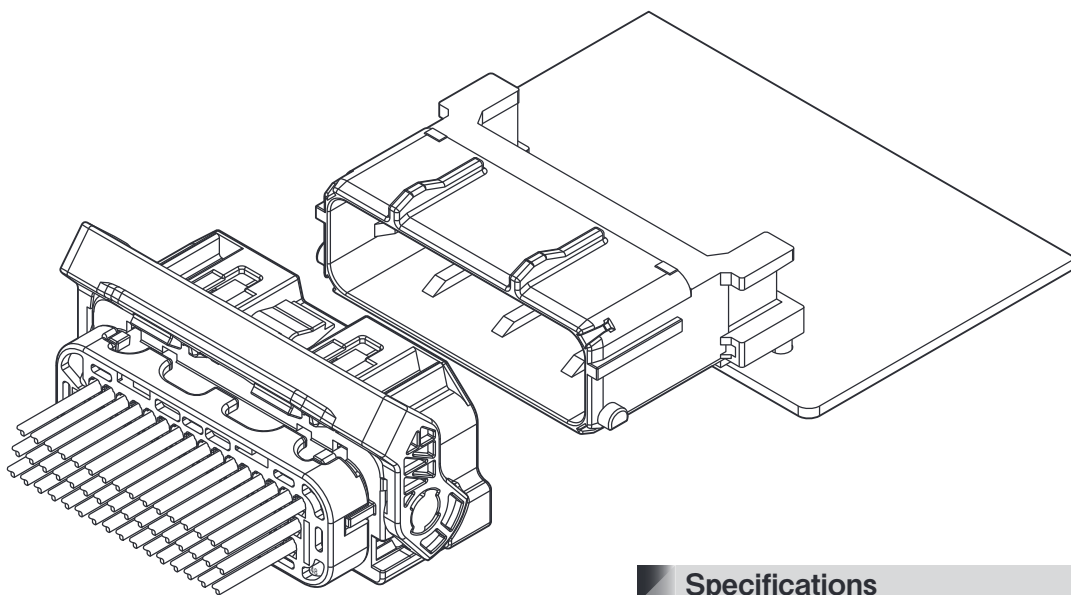

### Specifications

- **Current rating:** Power/ 7 A DC  
Signal/ 5 A DC
- **Voltage rating:** 50 V DC
- **Temperature range:** -40°C to +120°C  
(including temperature rise in applying electrical current)
- **Contact resistance:** Initial value/ 8 mΩ max.  
After environmental tests/ 16 mΩ max.
- **Insulation resistance:** 100 MΩ min.
- **Withstanding voltage:** 1,000 VAC/minute
- **Applicable wire:** AVSS 0.3 mm<sup>2</sup> to 0.85 mm<sup>2</sup>  
AESSX-f 0.3 mm<sup>2</sup> to 0.75 mm<sup>2</sup>

\* Compliant with ELV/RoHS.  
\* Contact JST for details.

## Female terminal

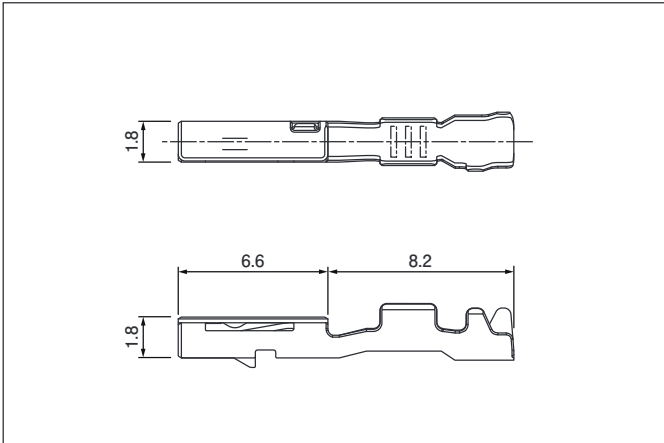

Model No.	Applicable wire range		Q'ty/reel
	Conductor (mm <sup>2</sup> )	Insulation O.D. (mm)	
SZRO-A021T-M0.64	0.3 to 0.5	1.4 to 1.7	10,000
SZRO-A031T-M0.64	0.75 to 0.85	1.8 to 1.9	10,000

### Material and Finish

Copper alloy, tin-plated (reflow treatment)

## Female connector

### ●36 circuits

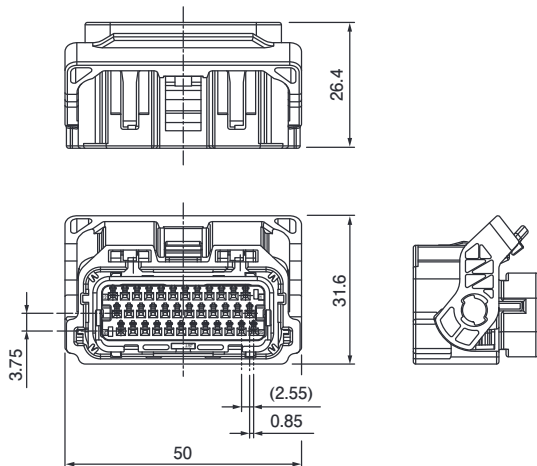

### ●48 circuits

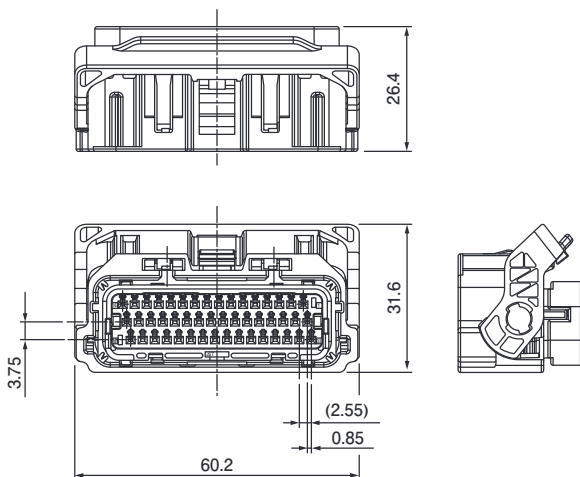

Circuits	Model No.	Key Code	Applicable wire range (mm <sup>2</sup> )	Q'ty/box	Housing Color	Wire seal Color
36	36ZRO-B-1A	A	0.5 to 0.85	512	Black	Brown
	36ZRO-B-2A	A	0.3 to 0.85 (Note)	512	Black	Red
	36ZRO-B-2B	B	0.3 to 0.85 (Note)	512	Gray	Red
48	48ZRO-B-1A	A	0.5 to 0.85	384	Black	Brown
	48ZRO-B-1B	B	0.5 to 0.85	384	Gray	Brown
	48ZRO-B-2A	A	0.3 to 0.85 (Note)	384	Black	Red
	48ZRO-B-2B	B	0.3 to 0.85 (Note)	384	Gray	Red

### Material and Finish

Housing: Glass-filled PBT  
Seal: Silicone  
Lever: POM

Note: There is a limit to an arrangement and number of wires when 0.75 mm<sup>2</sup> and 0.85 mm<sup>2</sup> wires applied. Refer to the drawing or contact JST for details.

# ZRO CONNECTOR

## Male connector

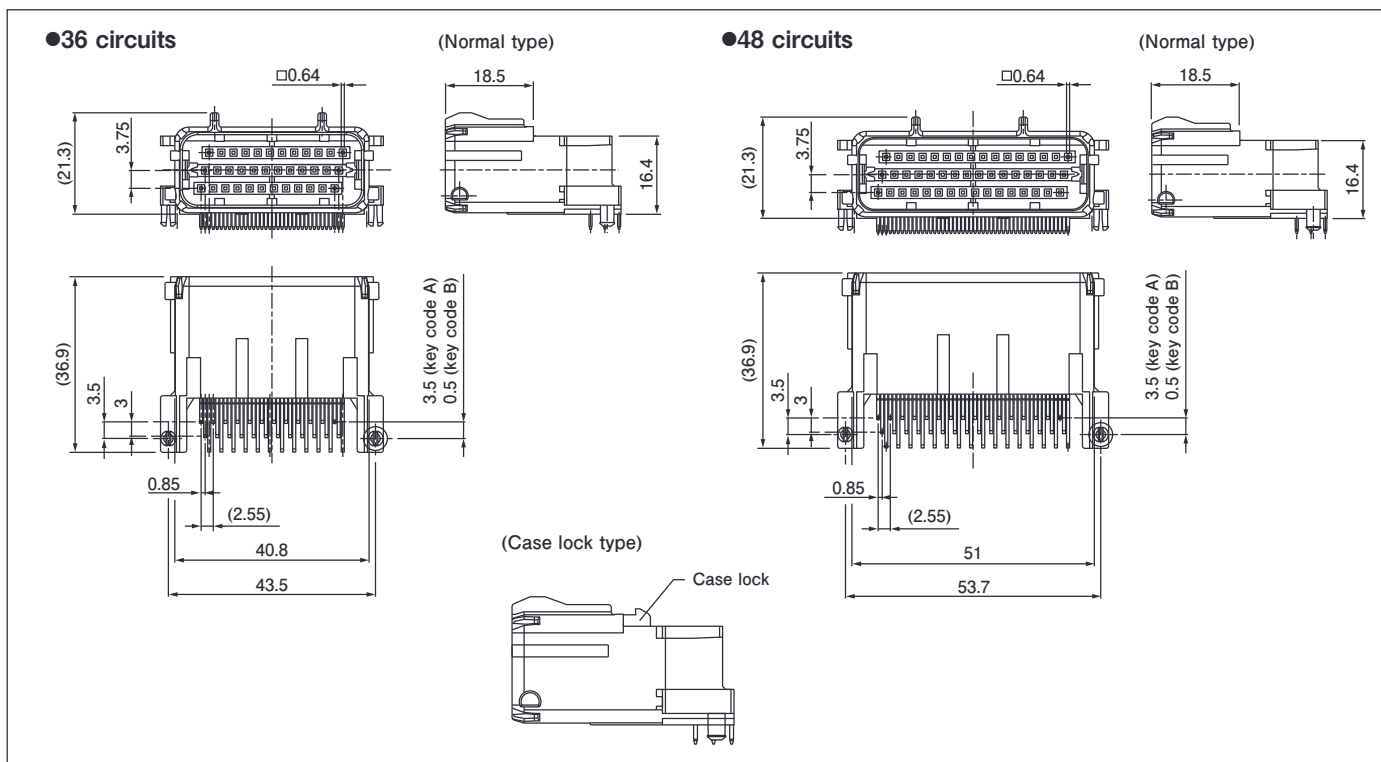

Type	Circuits	Model No.	Key Code	Q'ty/box	Housing Color
Normal	36	S36B-ZROK-2A-R	A	240	Black
		S36B-ZROH-2B-R	B		Gray
	48	S48B-ZROK-2A-R	A	192	Black
		S48B-ZROH-2B-R	B		Gray
Case lock	36	S36B-ZROK-3A-R	A	240	Black
		S36B-ZROH-3B-R	B		Gray
	48	S48B-ZROK-3A-R	A	192	Black
		S48B-ZROH-3B-R	B		Gray

### Material and Finish

Housing: Glass-filled PBT  
Pin: Brass, tin-plated (reflow treatment)

## Harness cover

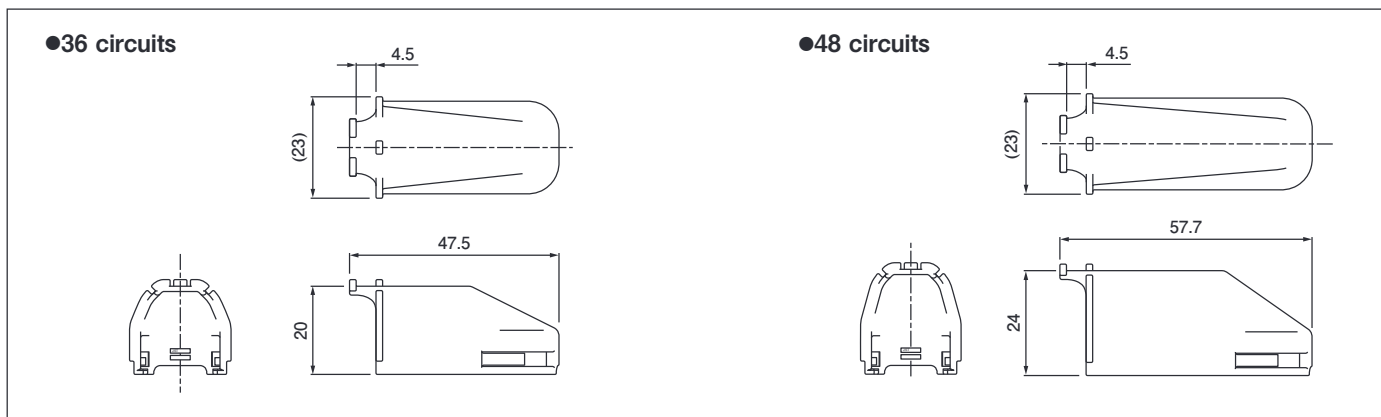

Circuits	Model No.	Q'ty/box	Housing Color
36	ZROHC-36H-K-1	900	Black
48	ZROHC-48H-K-1	600	Black

### Material and Finish

PBT

## Dummy plug

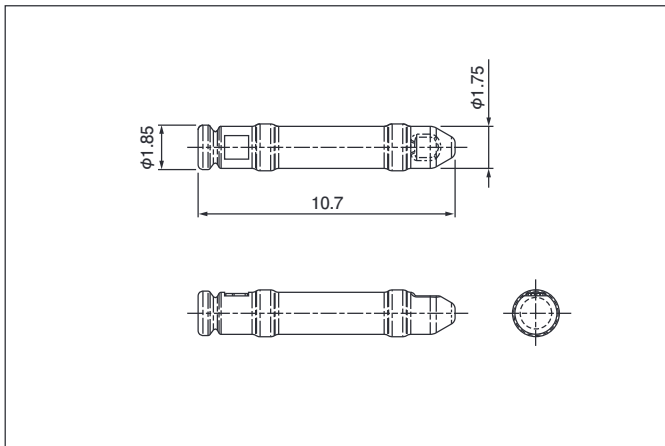

Model No.	Q'ty/box
WPHDP-H-1A-H	7,000
Material and Finish	
PBT, Gray	

## PC board layout, Assembly layout

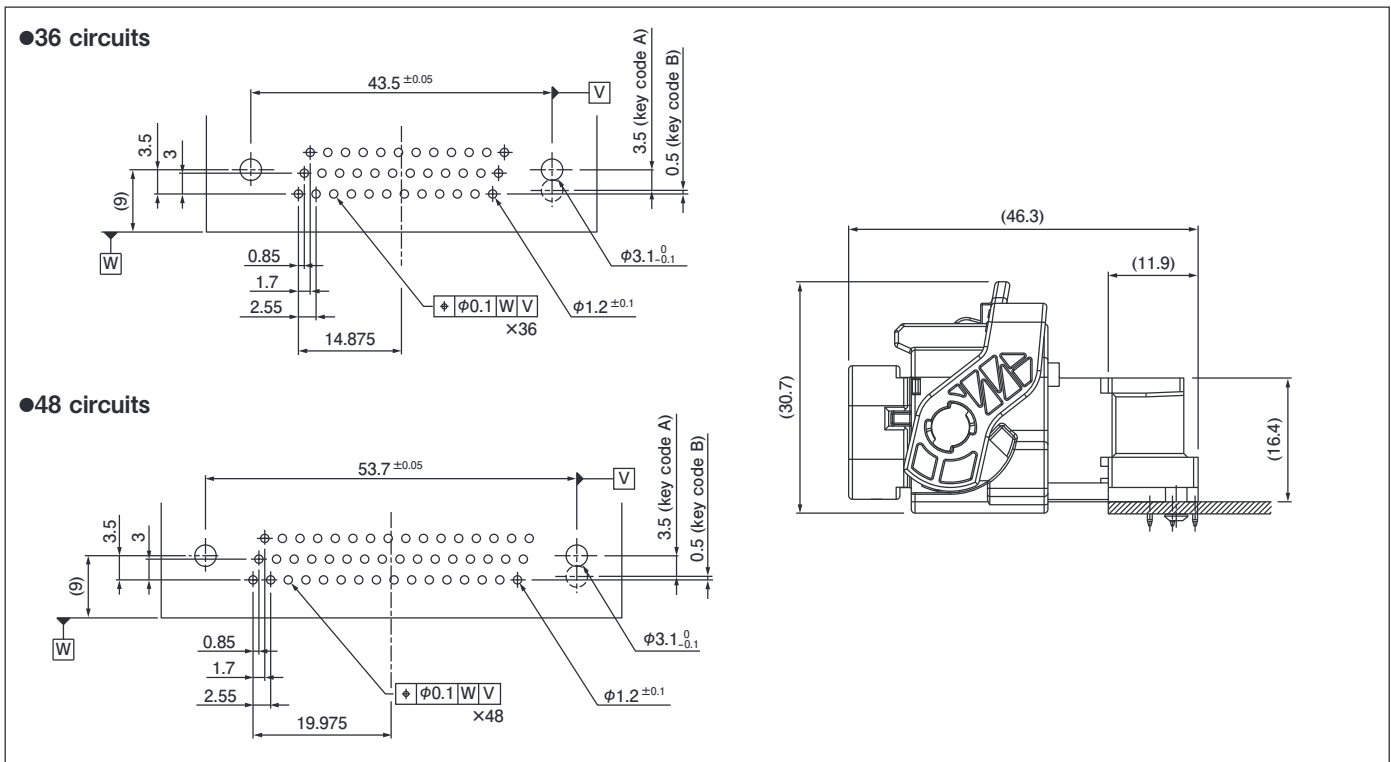

## Crimping machine, Applicator

Strip terminal	Crimping machine	Crimp applicator MKS-L	
		Dies	Crimp applicator with dies
SZRO-A021T-M0.64	AP-K2N	MK/SWPH-A021-064	APLMK SWPH-A021-064
SZRO-A031T-M0.64		MK/SZRO-A031-064	APLMK SZRO-A031-064

Note: When crimping operation is conducted using an applicator and die set other than the above, JST cannot guarantee the performance of the terminal.