

MaxiVAL® fuses are compliant with ISO 8820-3 Standard (Type “E”). This is the most applied standard to protect medium-heavy wires. Its slow blow operating characteristics allow high peak inrush currents with heavy duty cycle. MaxiVAL® are made of Zinc alloy whose low melting temperature avoids heavy over temperatures



Breaking capacity: 1000[A]
Voltage rating: 32[Vdc]
Ambient temperature: -40°C to +125°C

MTA/ISO MaxiVAL® operating time limits		
% I _N	min [s]	max [s]
100	360000	-
135	60	600 (*)
160	10	200
200	2	60
350	0,2	7
600	0,04	1

(*) Exceeds ISO requirements (900 Sec)

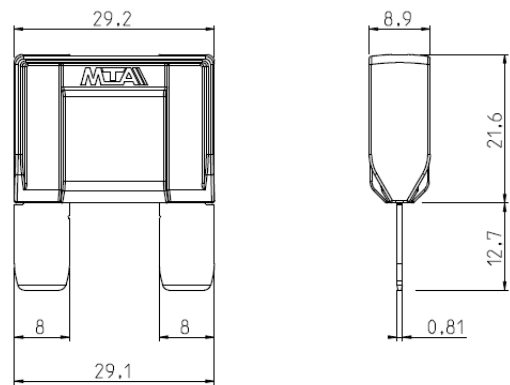

MaxiVAL® Operating Time
 @23°C test module ISO

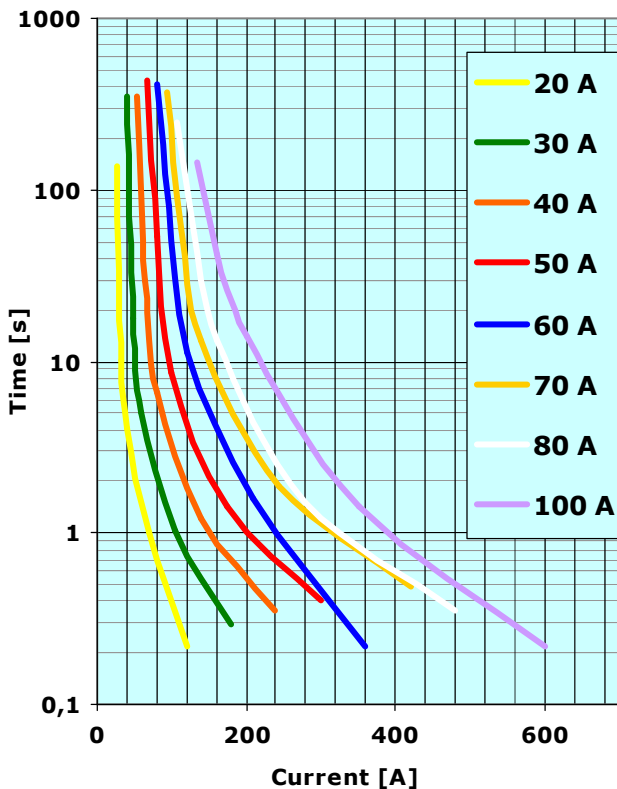

MaxiVAL® Re-Rating Curve.
 Test module ISO

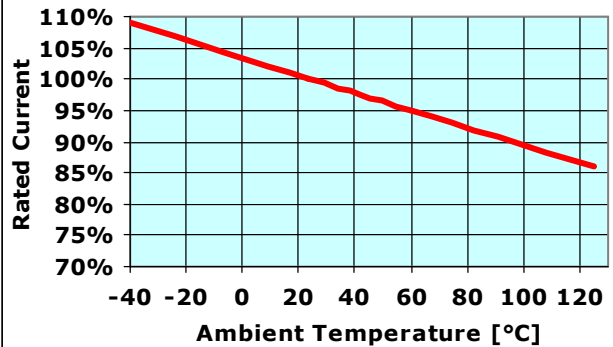

CURRENT RATING [A]	VOLTAGE DROP @ current rating [mV]	CABLE SIZE [mm ²]	I ² t
20	105	4,0	2880
30	95		7069
40	90		23120
50	89	6,0	36980
60	84		40680
70	87	10,0	112500
80	85		23120
100	89,5		65000