

SYMBOL DEFINITION		TOTAL NO OF INSPECTIONS REQUIRED	
A DIMENSION WITHOUT AN INSPECTION REPORT SYMBOL DOES NOT REQUIRE INSPECTION. IT MAY BE CONTROLLED ON THE INDIVIDUAL COMPONENT DRAWING.	(Symbol)	15	
	(Symbol)	15	

MISSING SYMBOLS		REVISION HISTORY		AUTH		DR		APVD	
DATE	STG	REV	N/P	CHG	ZONE	DATE	BY	DATE	BY
27FE04	R	02	-	-	REVISED PD	252119	MJM	MJM	MR
07SE04	R	03	-	-	12010300 - REVISED PER NIN EWO BGLTS ALL PARTS - REVISED TO	252892	MJM	MJM	MPR
120C04	R	04	-	-	12059168, 12059255 & 12066082 - REVISED NON PHYSICAL ECL TO AGREE WITH 1MSTR0318	259625	RTV	JVM	MPR
03SE07	R	05	-	-	ALL PARTS - REMOVED OPTIONAL CONSTRUCTIONS VIEWS & CONSTRUCTION LINE ALLOWABLE VIEWS; ADDED SEALING RIB NOTE, SEALING RIBS VIEWS, COLUMN "A" AND DIMS (2 PLCS)	402207	JBD	JVM	MPR
29SE08	R	06	-	-	13713913 - RELEASED	406277	RRR	AGN	RRR
15JA09	R	07	-	-	13750421 - RELEASED	407099	JBD	AUG	MPR
18MY09	R	08	-	-	13713913 - OBSOLETE	407723	RRR	JVM	RRR
03JA11	R	09	-	-	12059168 - ADDED ALTERNATE MATERIAL SPEC	412958	MAL	MAL	HAD
28JL17	R	10	-	-	35094687 - RELEASED	437361	JVM	JVM	CFH
03JA18	R	11	-	-	35094687 - REMOVED PART AVAILABILITY LINE & ADDED PART NUMBER TO NOTE 5.	438701	CFH	CFH	CFH
04JA18	R	12	-	-	35094687 - ADDED NOTE ON CHART	438708	CFH	CFH	CFH
22JA18	R	13	-	-	ADDED CHART REPLACED BY 12066082 - WILL BE REPLACED BY 35094687	438756	CFH	CFH	CFH
15FE18	R	14	-	-	12066082 - OBSOLETE; 12059255 - UPDATED PDM ATTRIBUTES	439057	LXA	JVM	CFH
29JA18	R	15	-	-	35232480 - RELEASED	440295	CGD	CGD	CEL
14JA19	R	16	-	-	35094687-OBSOLETE AND ADDED "REPLACED BY" INFO; 12066082-UPDATED "REPLACED BY" INFO (NO REV UPDATE REQ'D)	442075	JLL	JAA	CFH
26JL19	R	17	-	-	35241578 - RELEASED	444084	MH	SNS	KST

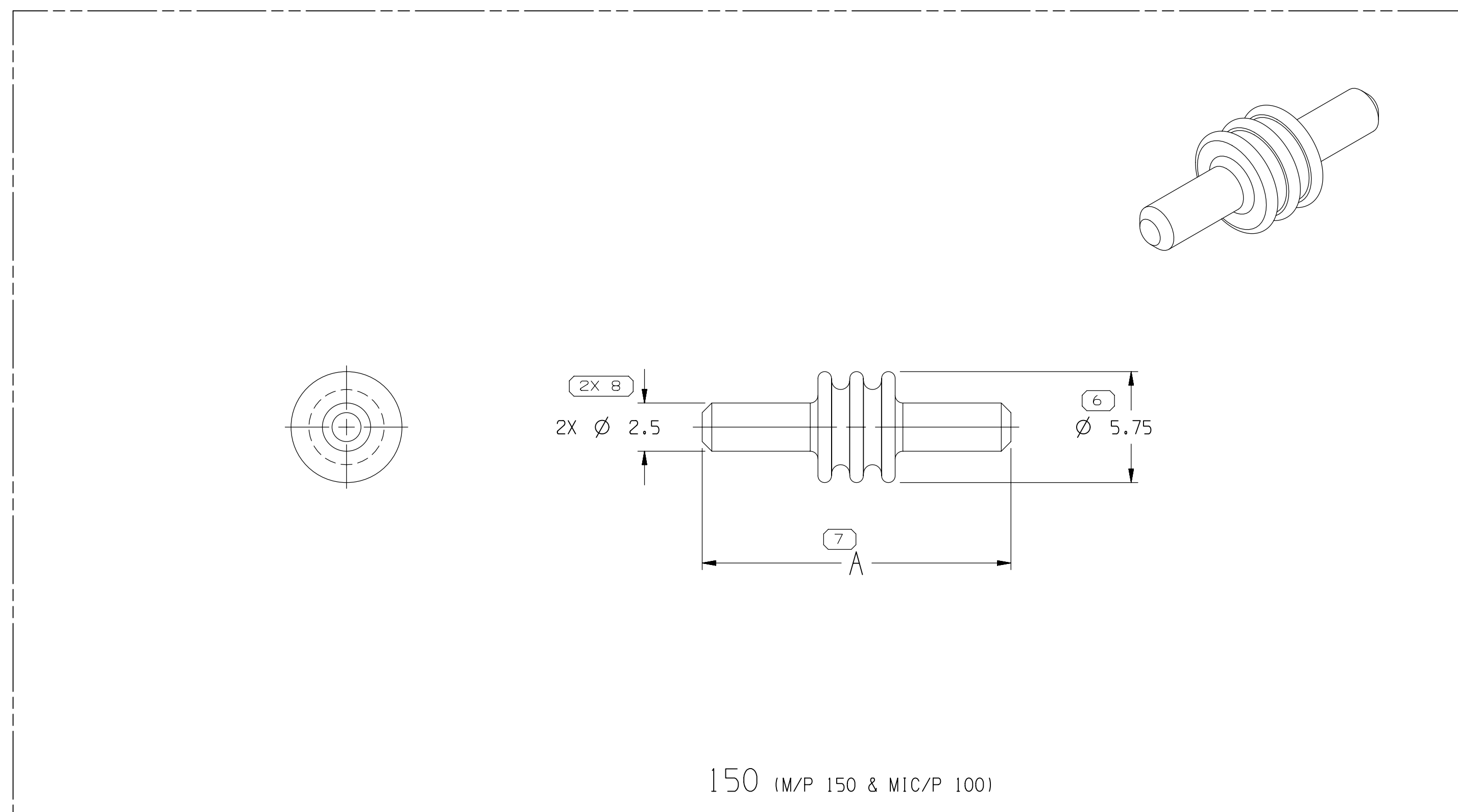

150 (M/P 150 & MIC/P 100)

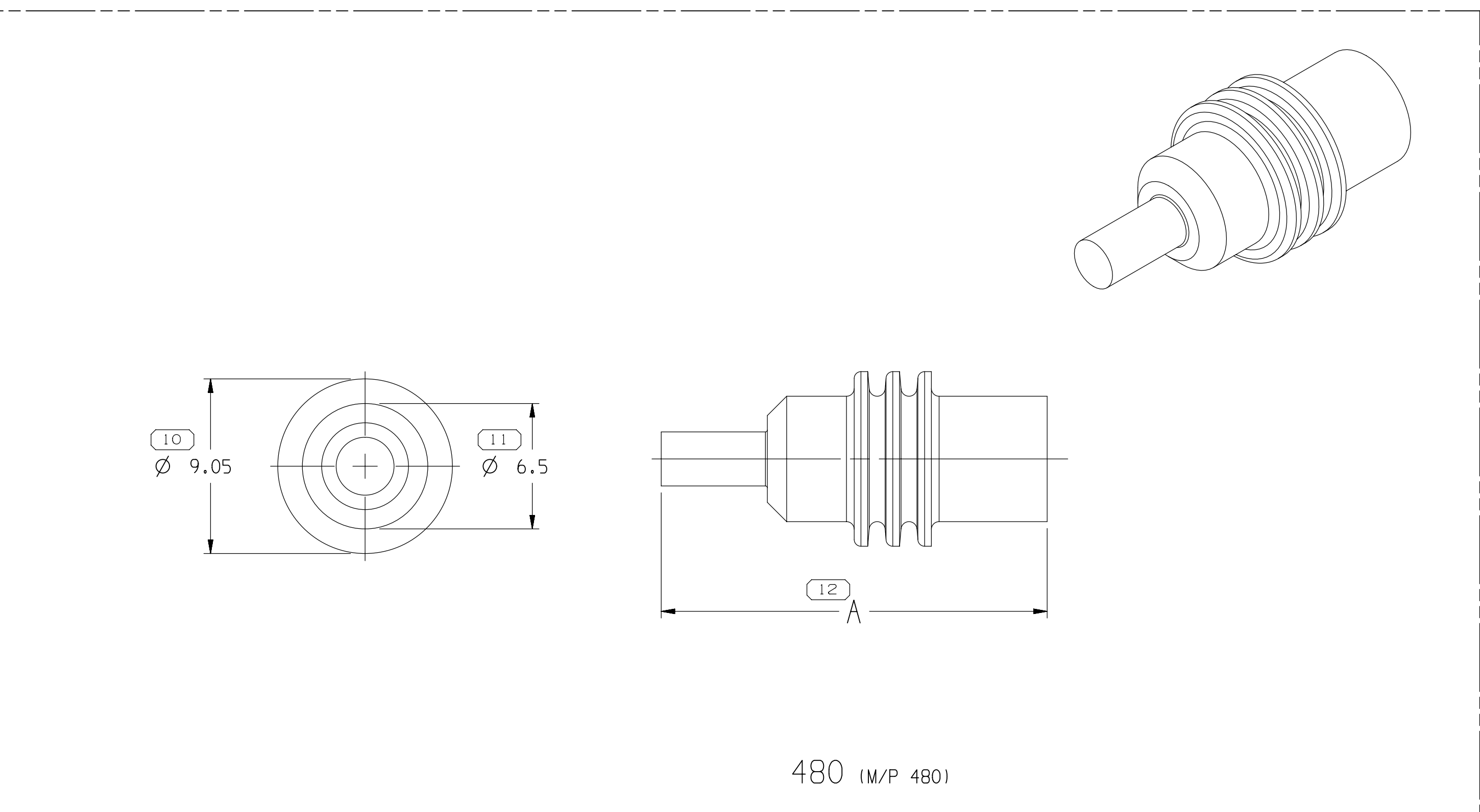

480 (M/P 480)

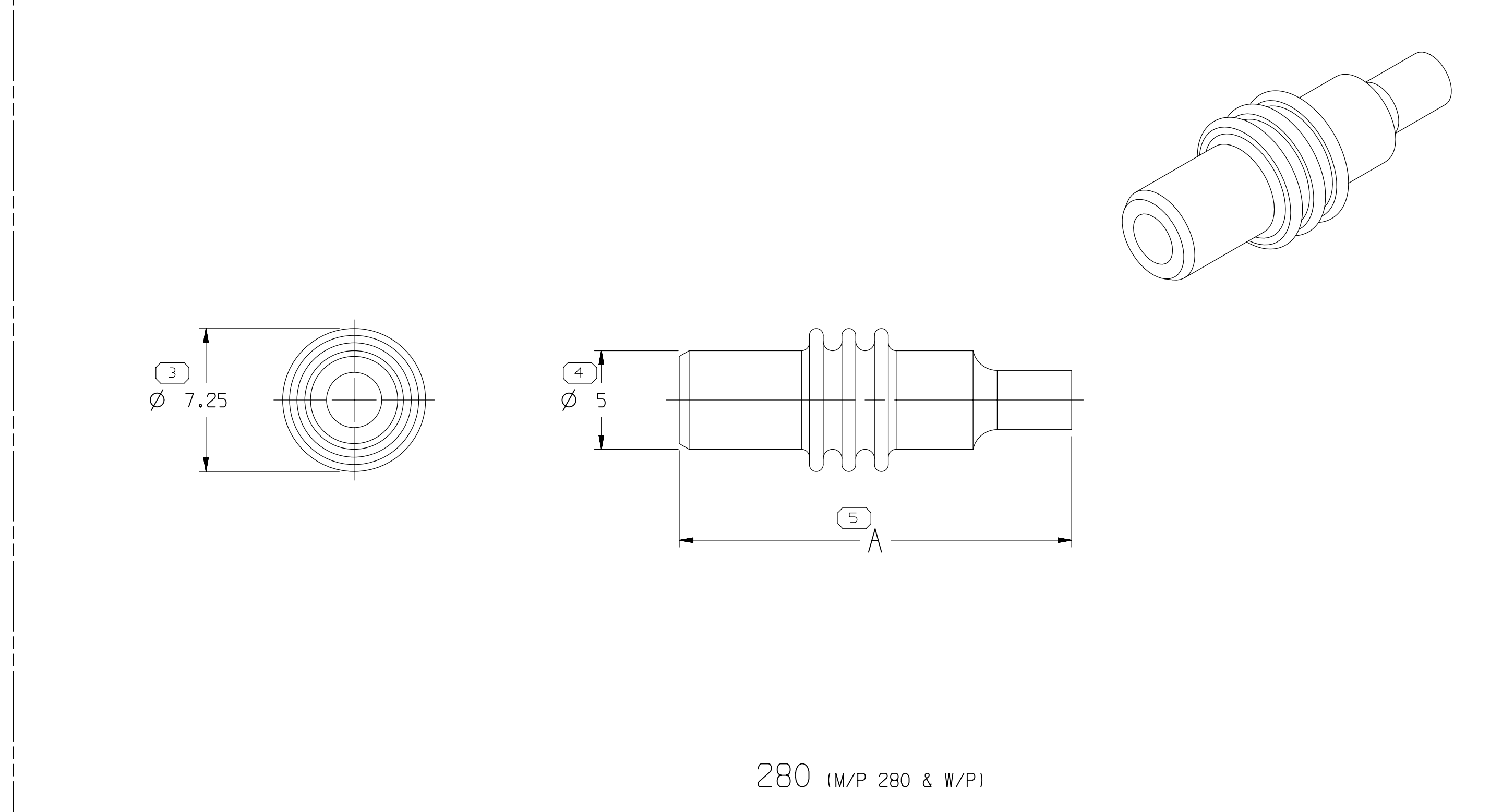

280 (M/P 280 & W/P)

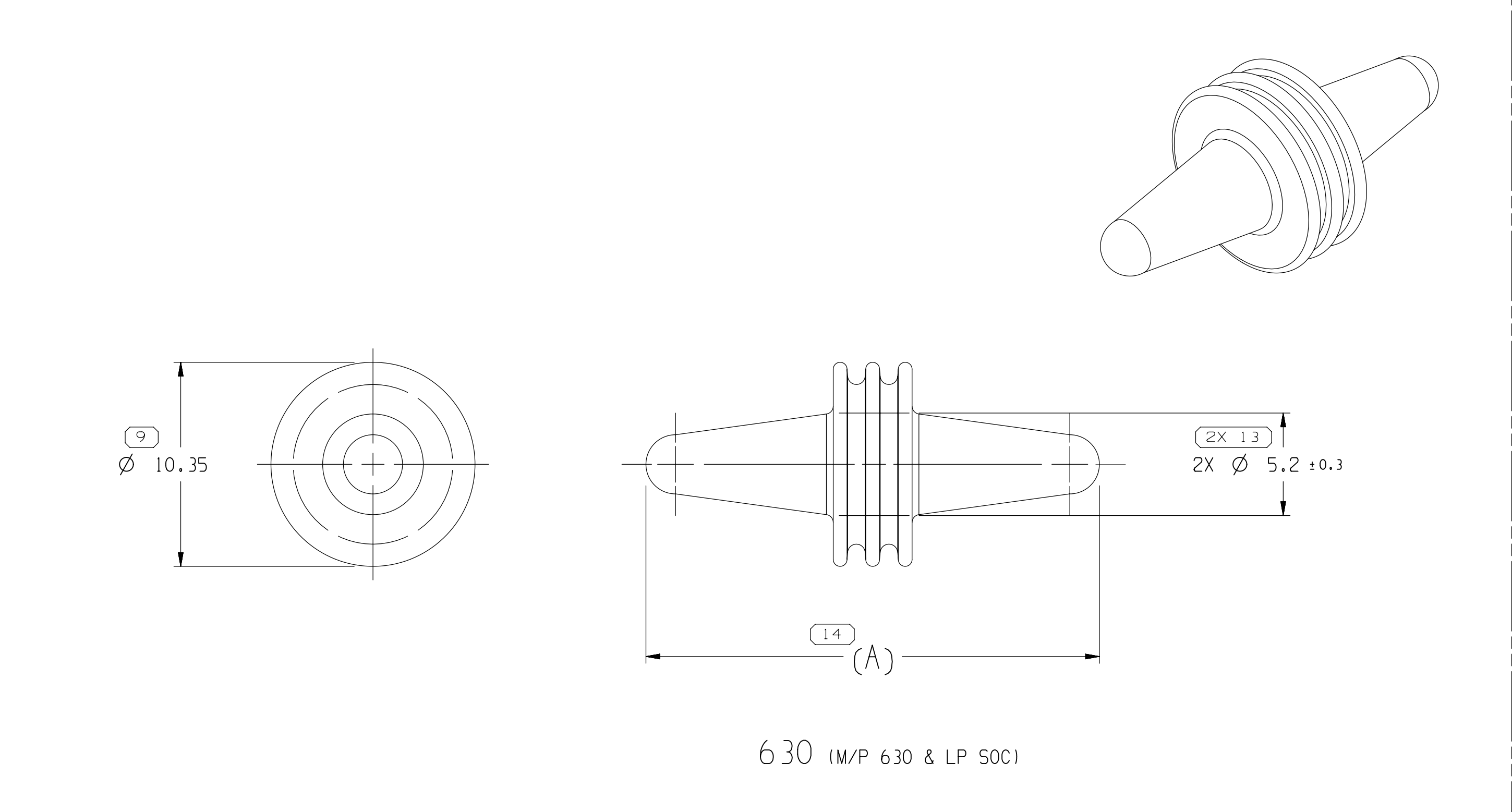

630 (M/P 630 & LP 500)

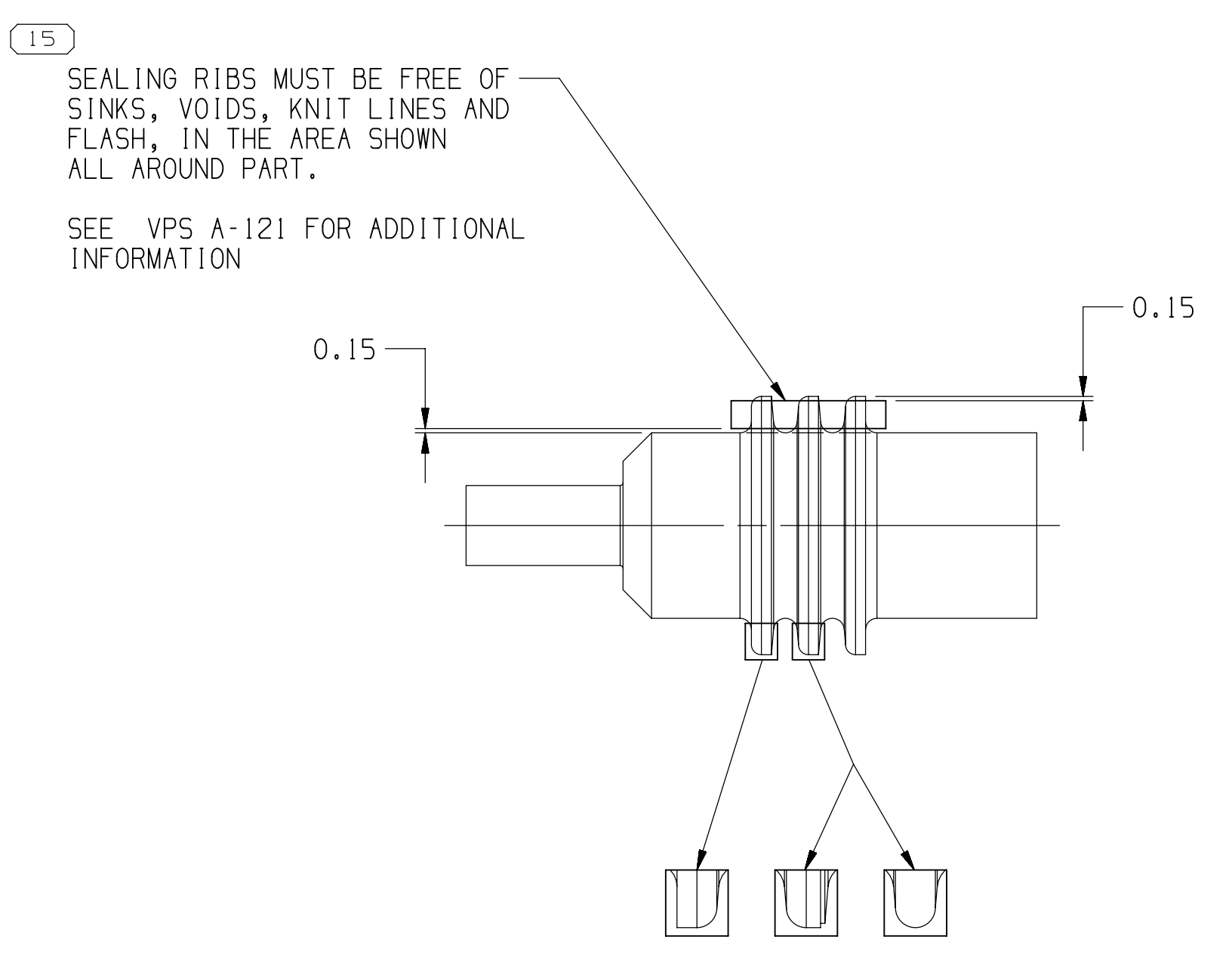

SEALING RIBS MAY DIFFER AS SHOWN

- NOTES
- UNLESS OTHERWISE SPECIFIED AND/OR INDICATED:
 - DIMENSIONS ARE TO FACE OF VIEW SHOWN AND AUTOMATICALLY ROUNDED BY COMPUTER FOR INSPECTION (SEE MATH MODEL FOR PRECISE DIMENSIONS). FOR ALL OTHER DIMENSIONS NOT SHOWN BUT REQUIRED FOR TOOL BUILD, SEE MATH MODEL FOR PRECISE TOOL PATH DATA.
 - SEALING RIBS ARE IDENTICAL, EXCEPT AS SHOWN.
 - THIS PART IS NOT CONTROLLED FOR AUTOMATIC FEEDING.
 - THIS PRODUCT IS NOT CATEGORIZED AS AN APPEARANCE ITEM, MINOR IMPERFECTIONS INCLUDING, BUT NOT LIMITED TO, FLOW MARKS, COLOR BLEMISHES, GATE VESTIGE, AND SOFT FLASH THAT DO NOT AFFECT THE FIT, FORM, OR FUNCTION OF THE PART ARE PERMISSIBLE PER EANP-4-3-CS-01-EN.
 - P/N 13713913 & 35094687 MUST BE POST-BAKED FOR 4 HOURS AT 400° F.

PART NO	REV	N/P	MATERIAL SPEC	COLOR (REF ONLY)	ALTERNATE MATERIAL SPEC	TYPE	A	ID CAVITY	VOLUME	NOTES	REPLACED BY
35241578	01	-	SILICONE METHYL/VINYL BLUE	BLU	-	150	16 ±0.3	5.2	0.135	-	-
35232480	01	-	SILICONE METHYL/VINYL GRAY	GRA	-	480	20 +0.45/-0.3	8.5	0.510	-	-
35094687	01	AC	SILICONE METHYL/VINYL GREEN	GRN	-	480	20 +0.45/-0.3	8.5	0.510	SEE NOTE 5	35232480
13750421	01	-	SILICONE METHYL/VINYL BLUE	BLU	-	280	19.9 ±0.4	6.7	0.311	-	-
13713913	01	AA	SILICONE METHYL/VINYL GREEN	GRN	-	150	16 ±0.3	5.2	0.135	-	-
12066082	B9	-	SILICONE METHYL/VINYL GREEN	GRN	-	480	20 +0.45/-0.3	8.5	0.510	SEE NOTE 5	35232480
12059255	A8	-	SILICONE METHYL/VINYL GREEN	GRN	M3469037	630	(23)	9.8	0.507	-	-
12059168	A9	-	SILICONE METHYL/VINYL RED	RED DK	M2261001	150	16 ±0.3	5.2	0.135	-	-
12010300	08	AA	SILICONE METHYL/VINYL GREEN	GRN	-	280	19.9 ±0.4	6.7	0.311	-	-

DIMENSIONAL RANGE (MM)	TOLERANCE	CHART	ET
FROM 0 TO >20	>0	>30	>70
20 TO >30	>0.1	>30	>70
30 TO >40	>0.15	>30	>70
40 TO >50	>0.2	>30	>70
50 TO >60	>0.25	>30	>70
60 TO >70	>0.3	>30	>70
70 TO >80	>0.35	>30	>70
80 TO >90	>0.4	>30	>70
90 TO >100	>0.45	>30	>70
100 TO >150	>0.5	>30	>70
150 TO >200	>0.6	>30	>70
200 TO >250	>0.7	>30	>70
250 TO >300	>0.8	>30	>70
300 TO >400	>1.0	>30	>70
400 TO >500	>1.2	>30	>70
500 TO >600	>1.5	>30	>70
600 TO >700	>2.0	>30	>70
700 TO >800	>2.5	>30	>70
800 TO >900	>3.0	>30	>70
900 TO >1000	>4.0	>30	>70

APTIV
CONNECTION SYSTEMS
WARREN, OH
COPYRIGHT 1997 APTIV. ALL RIGHTS RESERVED.

THIS DRAWING IS THE PROPERTY OF APTIV AND CONTAINS APTIV CONFIDENTIAL INFORMATION. THE REPRODUCTION, DISTRIBUTION AND UTILIZATION OF THIS DOCUMENT OR ITS RELATED CAD DATA, AS WELL AS COMMUNICATION OF ANY CONTENT TO OTHERS, WITHOUT EXPRESS AUTHORIZATION, IS PROHIBITED.

DATE: 18NO97
BY: A. DELGADO
DATE: 18NO97
BY: A. DELGADO
DATE: 18NO97
BY: J. BANZO

DRAWING NAME: TAXI SEAL CBL IW CAVITY PLUG
DRAWING NUMBER: 12124630

SIZE: A2
SCALE: 5:1
FRAME NO: 1 OF 1
SHEET NO: 1 OF 1
STG REV N/P: 1 R 17 -