

SYMBOL DEFINITION		TOTAL NO OF INSPECTIONS REQUIRED	MISSING SYMBOLS
A DIMENSION WITHOUT AN INSPECTION REPORT SYMBOL DOES NOT REQUIRE INSPECTION. IT MAY BE CONTROLLED ON THE INDIVIDUAL COMPONENT DRAWING.		10	4 6 9
		LAST NO. USED	10

DWG STATUS				REVISION HISTORY				AUTH		DR		APVD	
DATE	STG	REV	N/P	CHG	ZONE								
14JA00	R	001	-	-		CLEARED REV COLUMN: ALL ACTIVE PARTS-UPDATED PDM ATTRIBUTES	196648	CRW	GGI	LLD			
17JL00	R	002	-	-		REINSTATE 12077412	000010	JIB	JIB	JA			
15OC04	R	03	-	-		ALL ACTIVE PARTS - ADDED TERMINAL ID NOTE	260003	RTV	JVM	MKM			
24FE05	R	04	-	-		ALL ACTIVE PARTS - REVISED MAT'L SPEC & DRAWING NAME	265136	JS	JS	TM			
18MY05	R	05	-	-		12176389 - UPDATED PDM ATTRIBUTES	268280	JBD	FKV	WTM			
30SE05	R	06	-	-		12077411, 12077413, 12084201, 12129493 & 12176389 - UPDATED PDM ATTRIBUTES; 12077411 - ADDED 1.0 MM² CABLE; ALL ACTIVE PARTS - ADDED NOTE # 6	272905	JTV	AUG	WTM			
11JA08	R	07	-	-		ALL PARTS - 2X 5 +/-0.15 TYP WAS 2X 5 +/-0.01 TYP	403419	WHC	WHC	WTM			
18FE15	R	08	-	-		33231919 - RELEASED AND 12176387-90 - ADDED TARNISH NOTE	428904	NRM	JVM	DS			
18SE15	R	09	-	-		33231919 - DIM 19.95 +/-0.4 WAS 19.95 +/-0.15 / -0.4 AND UPDATED PART AVAILABILITY	430685	LES	LES	MD			
22MY19	R	10	-	-		12176387 - 3 WAS 5 ON SIZE (MM²) COLUMN	443374	LVD	JIE	JIE			

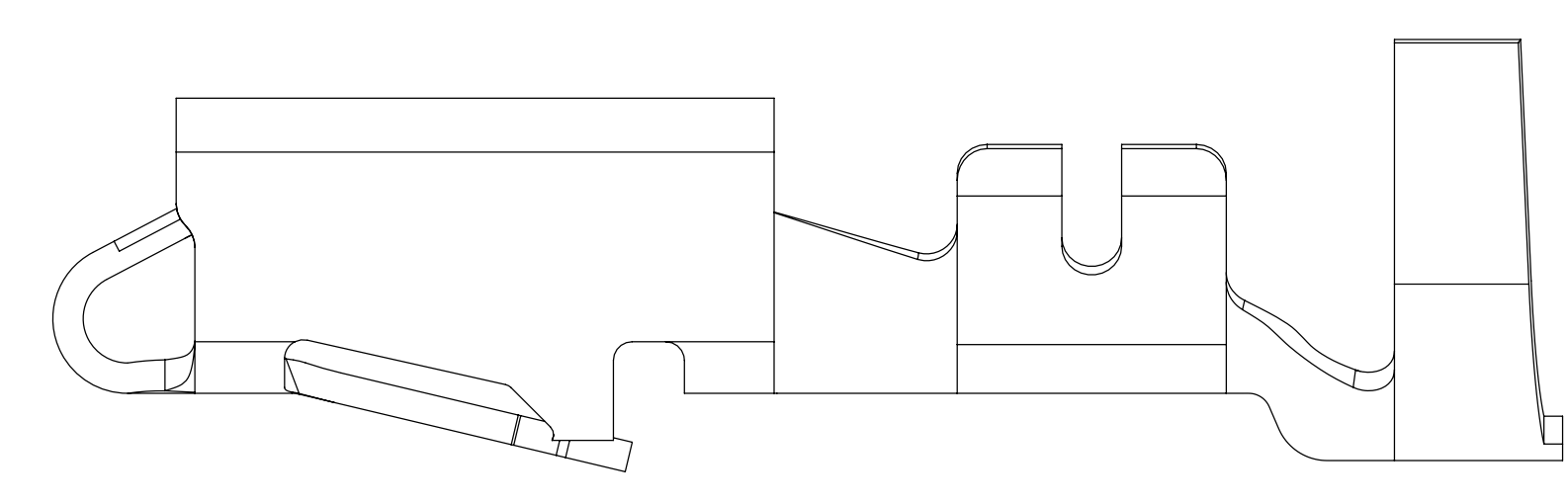

TYPE 102  
SAME AS TYPE 101  
EXCEPT AS SHOWN

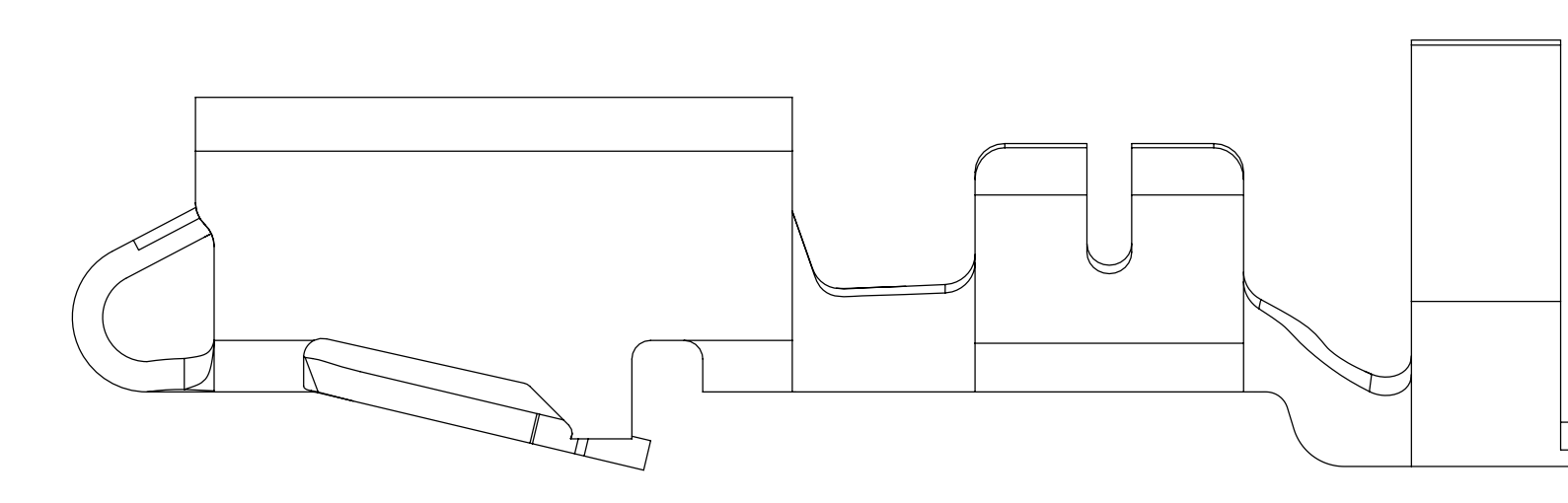

TYPE 103  
SAME AS TYPE 101  
EXCEPT AS SHOWN

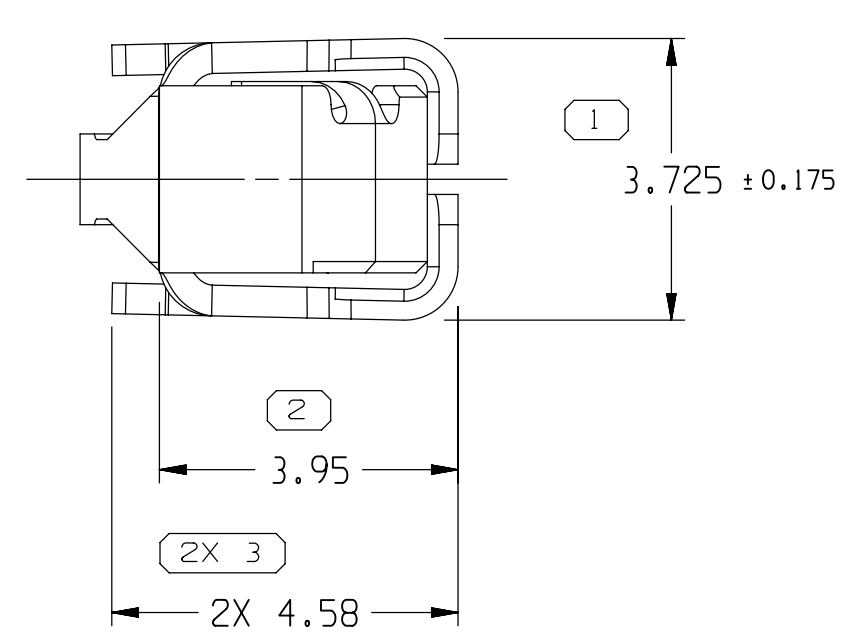
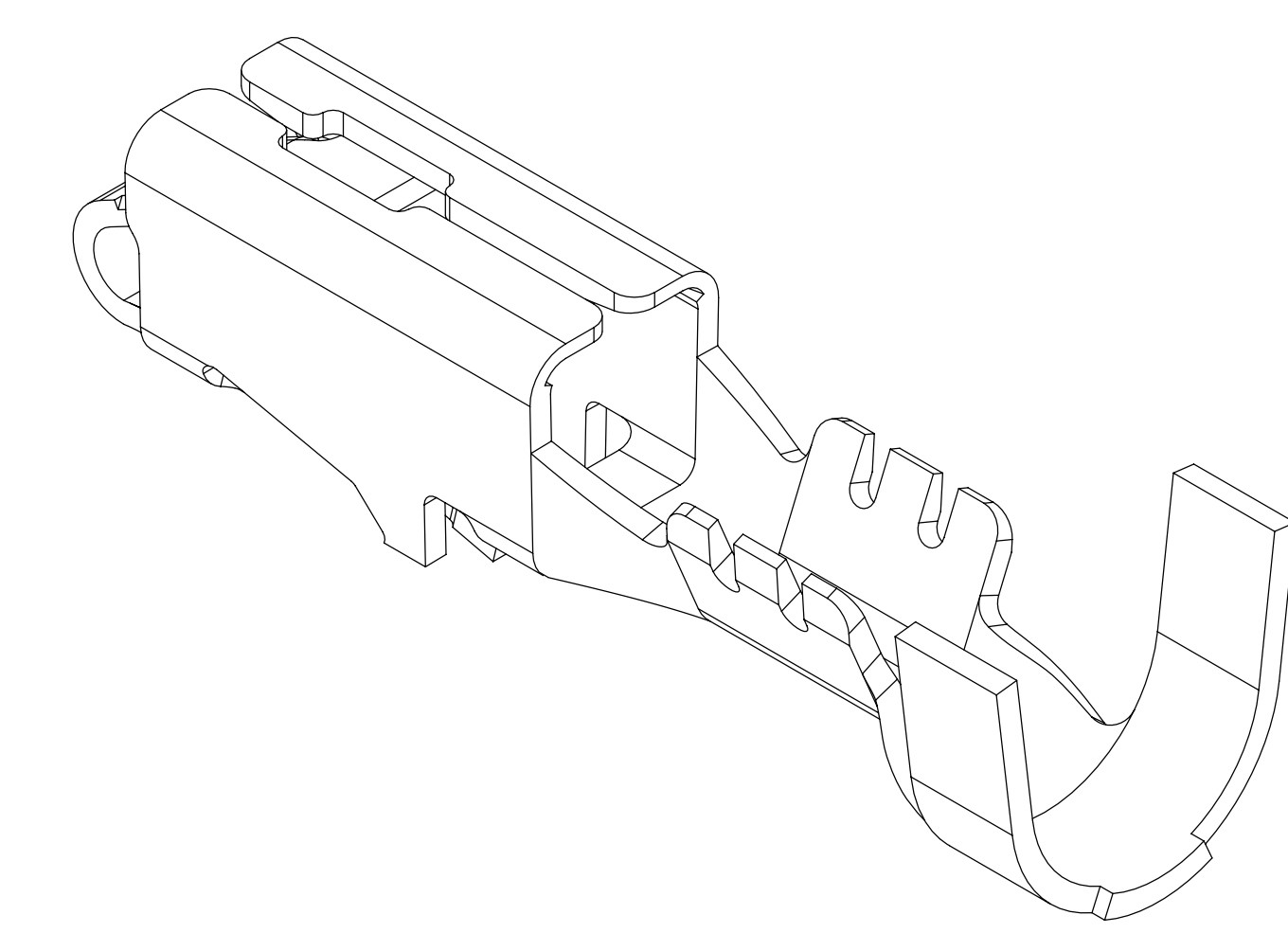

VIEW TO X-X

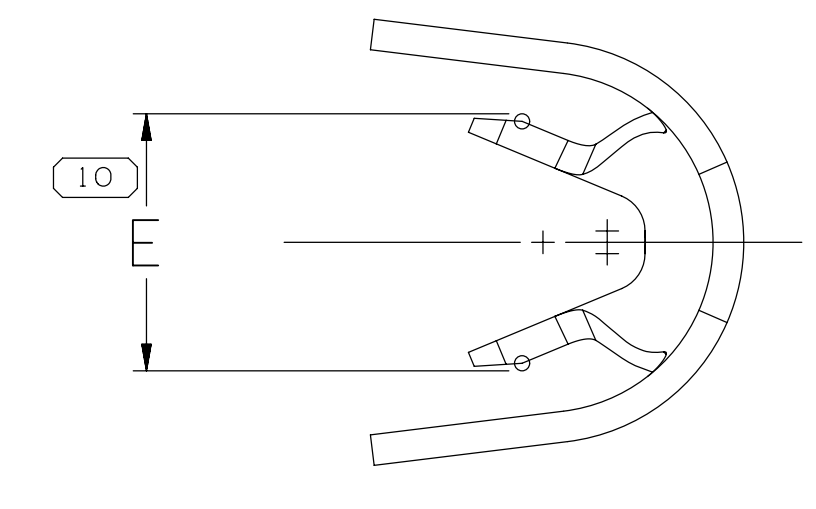
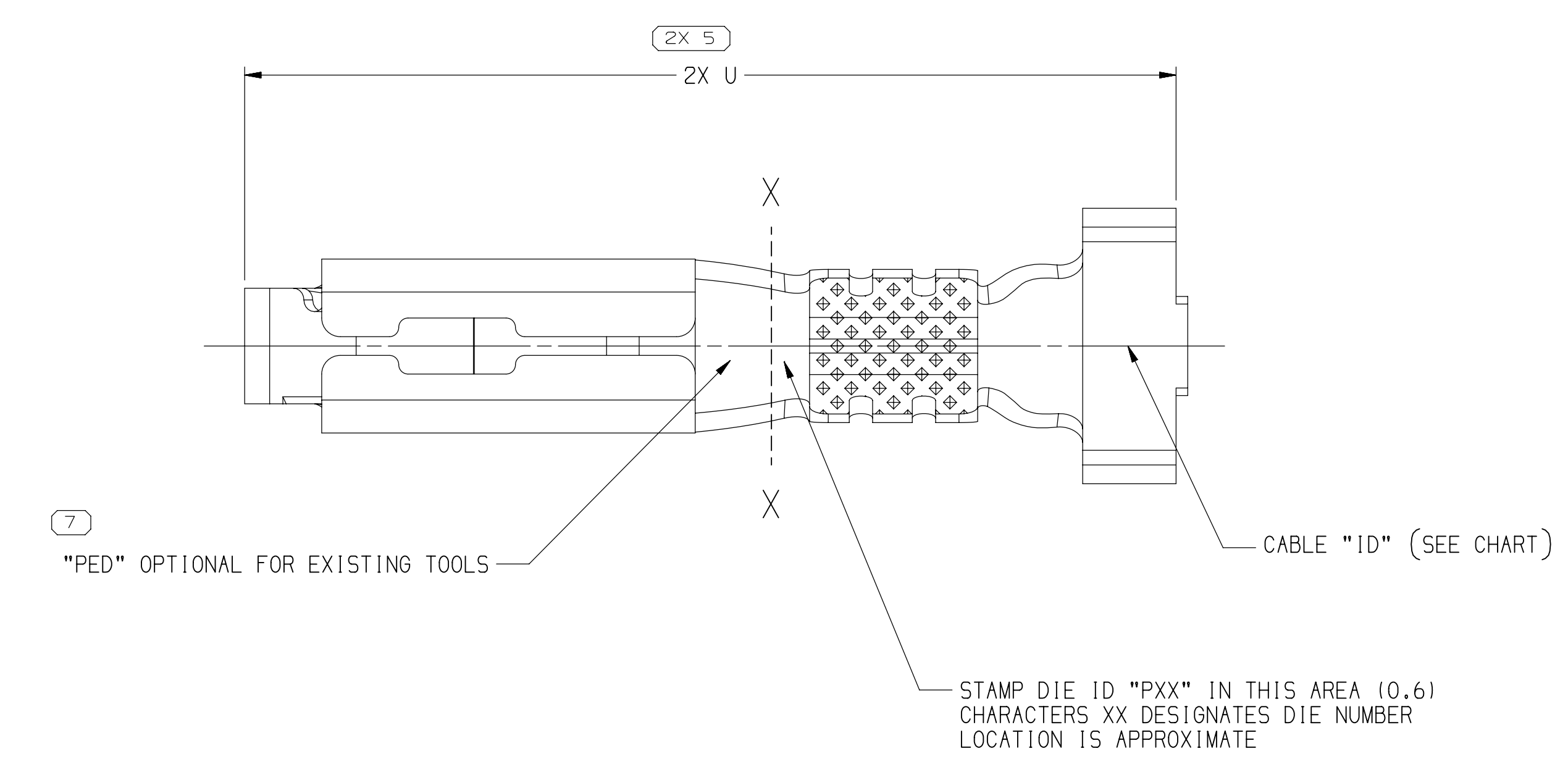

VIEW TO X-X

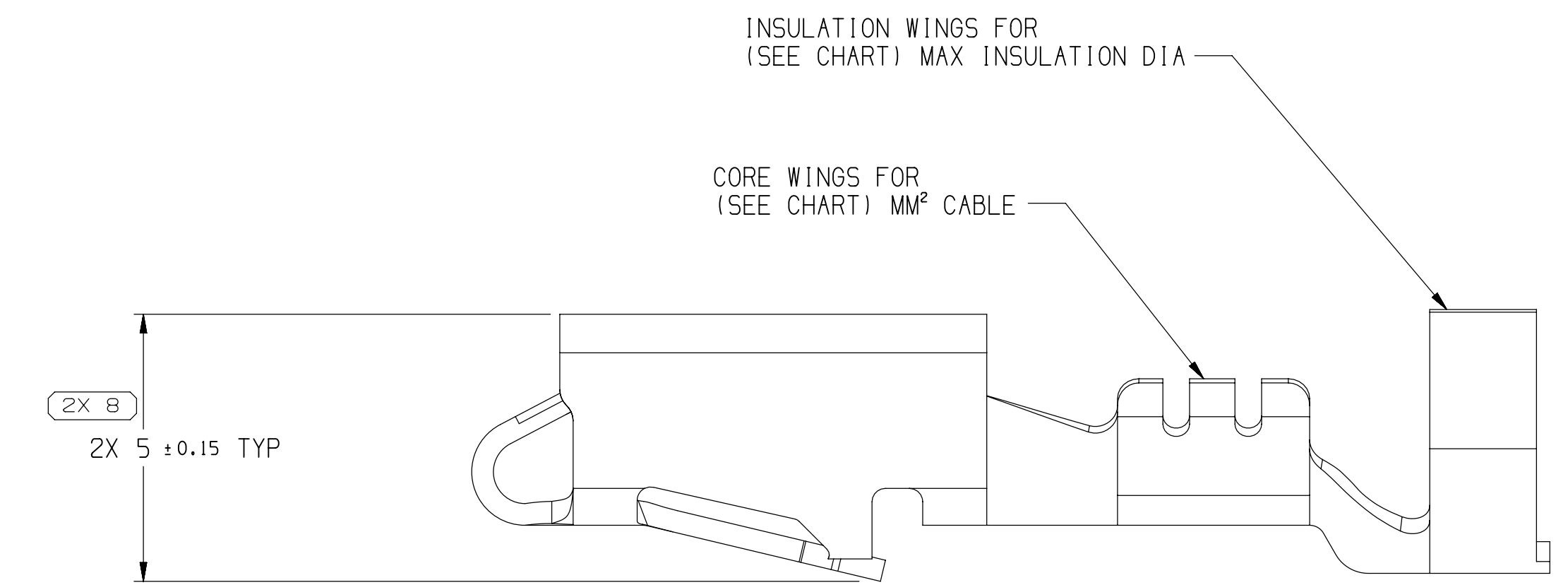

TYPE 101

NOTES

- UNLESS OTHERWISE SPECIFIED AND/OR INDICATED:  
DIMENSIONS ARE TO FACE OF VIEW SHOWN AND AUTOMATICALLY ROUNDED BY COMPUTER FOR INSPECTION (SEE MATH MODEL FOR PRECISE DIMENSIONS). FOR ALL OTHER DIMENSIONS NOT SHOWN BUT REQUIRED FOR TOOL BUILD, SEE MATH MODEL FOR PRECISE TOOL PATH DATA.
- R 0.4 PERMISSIBLE ON ALL "SHARP" CORNERS.
- RECOMMENDED MATING BLADE 2.8 X 0.81.
- TERMINALS TO CRIMP AROUND AND RETAIN CAVITY SEAL 12015323 OR EQUIVALENT.
- "PXX" INDICATES "P" PLUS LAST TWO DIGITS OF MAKE SERIES NUMBER (P01, P02, P03, ETC.).
- DO NOT PROBE, TEST OR OTHERWISE CONTACT THE INTERIOR REGION (THE SPRING OR ANY MOVING PART) OF THIS TERMINAL. SEVERE DAMAGE CAN OCCUR, COMPROMISING THE PERFORMANCE OF THE ELECTRICAL INTERFACE.
- FOR TERMINALS PACKAGED & STORED IN THE APPROVED MANNER, TARNISH ON SILVER PLATED SURFACES WILL NOT AFFECT THE PERFORMANCE OF THE PART.

PART NO	REV	MAT'L SIZE	SPEC	PART NO	REV	N/P	PLATED	MAT'L SPEC	SIZE (MM²)	CABLE	DIA	ID	TYPE
-	-	0.406 X 30.56	-	12176390	A8	-	-	A6 PLATED COPPER ALLOY	0.35-0.5	0.35-0.5	21	103	2.4+0.2
-	-	0.406 X 30.56	-	12176389	A9	-	-	A6 PLATED COPPER ALLOY	0.8-1	2.03-3.12	19	101	3.2+0.4
-	-	0.406 X 30.56	-	33231919	O1	AA	-	A6 PLATED COPPER ALLOY	1-2	2.48-3.05	15	103	3.7+0.4
-	-	0.406 X 30.56	-	12176388	A8	-	-	A6 PLATED COPPER ALLOY	2-3	2.45-3.80	13	103	4+0.4
-	-	0.406 X 30.56	-	12176387	A9	-	-	A6 PLATED COPPER ALLOY	3	3.49-3.65	12	103	4.6+0.4
-	-	0.406 X 30.56	-	12129493	C8	-	-	TIN PLATED COPPER ALLOY	2-3	2.45-3.80	13	103	4+0.4
-	-	0.406 X 30.56	-	12084201	E11	-	-	TIN PLATED COPPER ALLOY	0.35-0.5	1.84-2.51	21	101	2.4+0.2
-	-	0.406 X 30.56	-	12077413	E11	-	-	TIN PLATED COPPER ALLOY	3	3.49-3.65	12	103	4.6+0.4
-	-	0.406 X 30.56	-	12077412	E9	-	-	TIN PLATED COPPER ALLOY	1-2	2.48-3.05	15	103	3.7+0.4
-	-	0.406 X 30.56	-	12077411	E11	-	-	TIN PLATED COPPER ALLOY	0.5-0.8-1.0	2.03-3.12	19	101	3.2+0.4
-	-	0.406 X 32.54	-	12045639	D8	-	-	P1519027 425 TIN BR5 EX HD SN PLTD	3	3.49-3.65	12	102	4.6+0.4
-	-	0.406 X 32.54	-	12034454	F8	-	-	P1519027 425 TIN BR5 EX HD SN PLTD	1-2	2.48-3.05	15	102	3.7+0.4
-	-	0.406 X 32.54	-	12020648	H8	-	-	P1519027 425 TIN BR5 EX HD SN PLTD	0.5-0.8	2.03-3.12	19	101	3.2+0.4
-	-	0.406 X 32.54	-	-	-	-	-	-	-	-	-	-	-

DIMS TYPE		PART DRAWING	
STYLE		DISTR CODE	D
VOLUME (CM³)			
UNLESS OTHERWISE SPECIFIED			
THIS DOCUMENT IS IN ACCORDANCE WITH ASME Y14.5M-1994 AS AMENDED BY THE 2003 GLOBAL DIMENSIONING AND TOLERANCING ADDENDUM-2003. SEPARATE PATTERNING OF FEATURES MAY BE ORDERED SEPARATELY REGARDLESS OF DATUM REFERENCES.			
ALL DIMENSIONS ARE IN MILLIMETERS			
REFERENCE			
THIRD ANGLE PROJECTION			
DO NOT SCALE USE MATH DATA			
ANGULAR TOLERANCE ±2°			

**• APTIV •**  
CONNECTION SYSTEMS  
WARREN, OH  
COPYRIGHT 1998 APTIV. ALL RIGHTS RESERVED.  
THIS DRAWING IS THE PROPERTY OF APTIV AND CONTAINS APTIV CONFIDENTIAL INFORMATION. THE REPRODUCTION, DISTRIBUTION AND UTILIZATION OF THIS DOCUMENT OR ITS RELATED CAD DATA, AS WELL AS COMMUNICATION OF ANY CONTENT TO OTHERS, WITHOUT EXPRESS AUTHORIZATION, IS PROHIBITED.

DR: JORGE IBARRA  
APVD1: OSCAR OCHOA  
APVD3: O. GALLEGOS  
APVD4: [Signature]

DATE: 29MY98  
02JN98  
16JL98

SUBSTANCES OF CONCERN AND RECYCLED CONTENT PER APTIV 10499001

DRAWING NUMBER: TAXI TERM F M/P 280 SEALED

12089195

SIZE: A0  
SCALE: 10:1  
FRAME NO: 1 OF 1  
SHEET NO: 1 OF 1  
STG REV N/P: R 10 -