

SYMBOL DEFINITION		MISSING NUMBERS	
A DIMENSION WITHOUT AN INSPECTION REPORT SYMBOL  DOES NOT REQUIRE INSPECTION. IT MAY BE CONTROLLED ON AN INDIVIDUAL COMPONENT DRAWING.	TOTAL NO. OF SYMBOLS ON DRAWING	9	
	LAST NO. USED	15	

DWG STATUS					ZONE	REVISION HISTORY	AUTH	DR	APVD1	APVD2
DATE	STG	REV	N/P	CHG						
26AP99	R	001	-	-		CLEARED REVISION COLUMN & ALL PARTS - UPDATED PDM ATTRIBUTES	193698	ROM	JHV	RF
30AU99	R	002	-	-		12176636 - REVISED MAT'L SPEC	196828	HGH	HGH	JR
15AU01	R	003	-	-		ALL PARTS - REVISED MAT'L SPEC	211578	ESF	EAR	GMC
17FE04	-	04	-	-		ALL PARTS - T.O.D. UPDATED	250621	JS	JS	BG
20SE05	R	05	-	-		ALL PARTS - 2X 2.95 MAX WAS 2X 2.95, ADDED UNPLATED CHART, ADDED STAMP CABLE I.D. NOTE AND NOTES 3 & 4	271405	TAI	TAI	BG

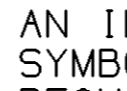
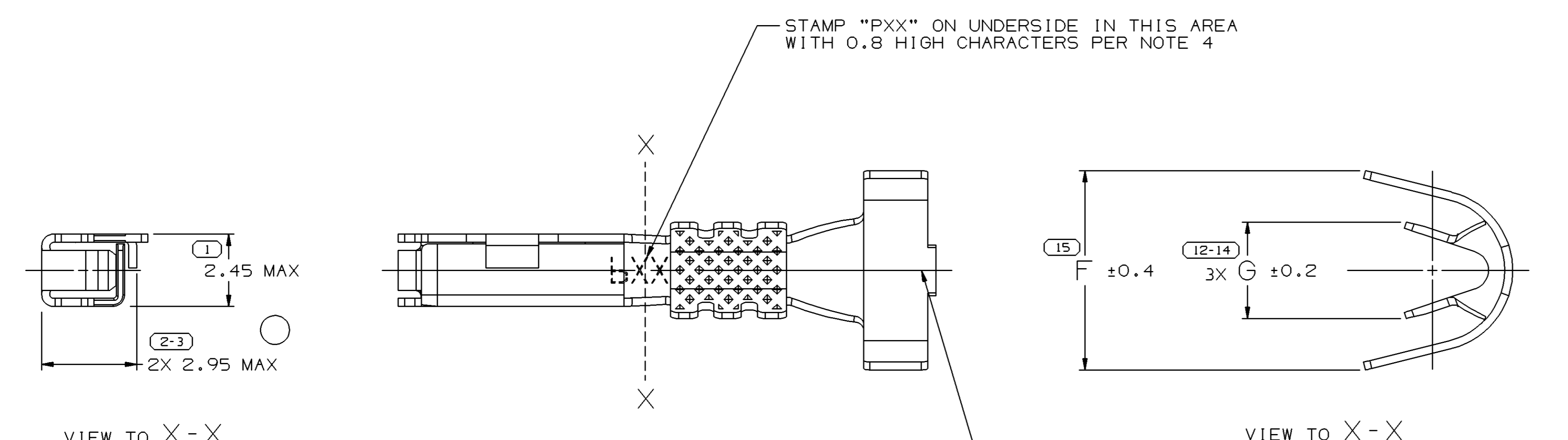

STAMP "PXX" ON UNDERSIDE IN THIS AREA WITH 0.8 HIGH CHARACTERS PER NOTE 4

STAMP CABLE I.D. NO. ON UNDERSIDE IN THIS AREA WITH 0.8 HIGH CHARACTERS SHOWN IN CHART.

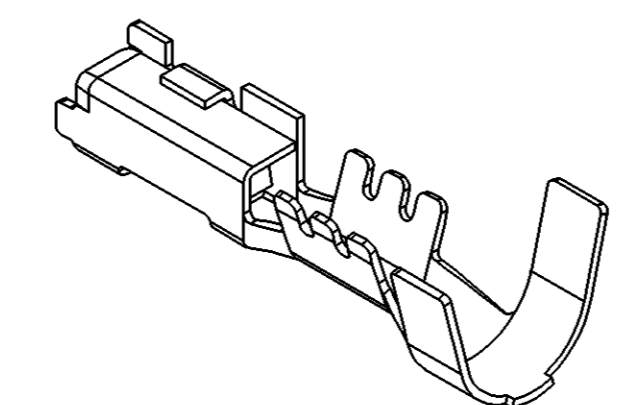
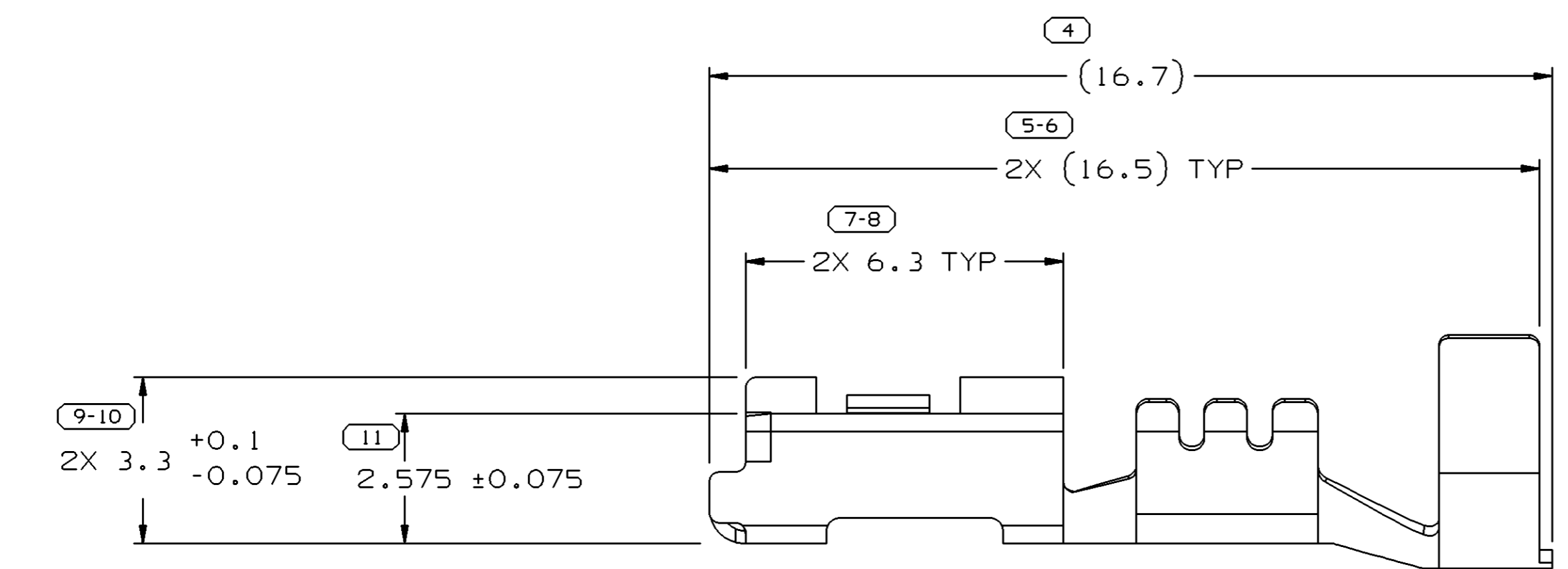

VIEW SCALE DOES NOT REFLECT ACTUAL PART SIZE

NOTES

- UNLESS OTHERWISE SPECIFIED AND/OR INDICATED:
DIMENSIONS ARE TO FACE OF VIEW SHOWN AND AUTOMATICALLY ROUNDED BY COMPUTER FOR INSPECTION (SEE MATH MODEL FOR PRECISE DIMENSIONS). FOR ALL OTHER DIMENSIONS NOT SHOWN BUT REQUIRED FOR TOOL BUILD, SEE MATH MODEL FOR PRECISE TOOL PATH DATA.
- RECOMMENDED MATING BLADE - WIDTH:1.64/1.4
THICKNESS:0.86/0.79
LENGTH:7.1/6.9
- DO NOT PROBE, TEST OR OTHERWISE CONTACT THE INTERIOR REGION (THE SPRING OR ANY MOVING PART) OF THIS TERMINAL. SEVERE DAMAGE CAN OCCUR, COMPROMISING THE PERFORMANCE OF THE ELECTRICAL INTERFACE.
- "PXX" INDICATES "P" PLUS LAST TWO DIGITS OF MAKE DIE SERIES NUMBER (P01, P02, P03, ETC).

PART NO	REV	N/P	STATUS	MAT'L SIZE	MAT'L SPEC	PART NO	REV	N/P	STATUS	MAT'L SIZE	MAT'L SPEC	SIZE (MM²)	ID	Ø	F	G
				0.254 X 29.80	M3604401 NONFERROUS C5400 1/2 HD	12176637	04	AA		M3606929 NONFERROUS C5400 1/2 HD	0.5-0.35	21	2.2-1.3	6.2	2.1	
				0.254 X 29.80	M3604401 NONFERROUS C5400 1/2 HD	12176636	04	AA		M3606929 NONFERROUS C5400 1/2 HD	1-0.8	60	2.8-2.03	6.2	3	
UNPLATED						PLATED						CABLE				

15 PROCESS SENSITIVE DIMENSION	
DIMENSIONS ENCLOSED IN () INDICATE REFERENCE DIMENSIONS AND NO TOLERANCE LIMITS ARE ESTABLISHED	
DIMENSIONAL RANGE (MM)	CHART D
FROM 0	>12
TO 12	
TOLERANCE UNLESS OTHERWISE SPECIFIED	
±0.1	±0.2
ANGULAR TOLERANCE ±2°	

DWG TYPE: PART DRAWING

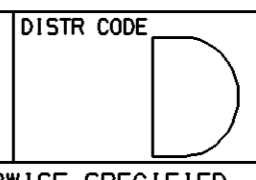
STYLE: 

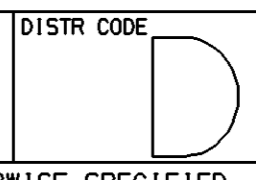
VOLUME (CM³): 

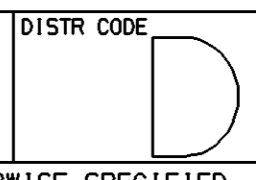
DISTR CODE: 

UNLESS OTHERWISE SPECIFIED
THIS DOCUMENT IS IN ACCORDANCE WITH ASME Y14.5M-1994 AS AMENDED BY THE GM GLOBAL DIMENSIONING AND TOLERANCING ADDENDUM-2001. SEPARATE PATTERNS OF FEATURES MAY BE GAGED SEPARATELY REGARDLESS OF DATUM REFERENCES.

ALL DIMENSIONS ARE IN MILLIMETERS

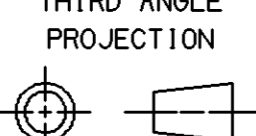
THIRD ANGLE PROJECTION 

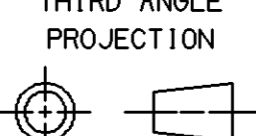
DO NOT SCALE 

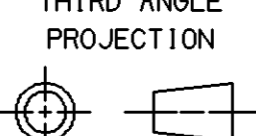
USE MATH DATA 

UNIGRAPHICS 

DELPHI

DELPHI PACKARD ELECTRIC SYSTEMS
WARREN, OH

DR	DATE
APVD1 C. RAMIREZ	12AP96
APVD2 PEDRO YABUR	17AP96
APVD3 R.J. POLENICK	30AP96
APVD4	
APVD5	

SUBSTANCES OF CONCERN AND RECYCLED CONTENT PER DELPHI 10949001

MATERIAL SEE DWG

DRAWING NAME: TAXI TERM F M/P 150

DRAWING NUMBER: 12191664

SIZE A1	SCALE 10:1	FRAME NO 1 OF 1	SHEET NO 1 OF 1	STG R	REV 05	N/P -
---------	------------	-----------------	-----------------	-------	--------	-------