

OPTIONAL CONSTRUCTION 1  
(ANTI-STICK RING)

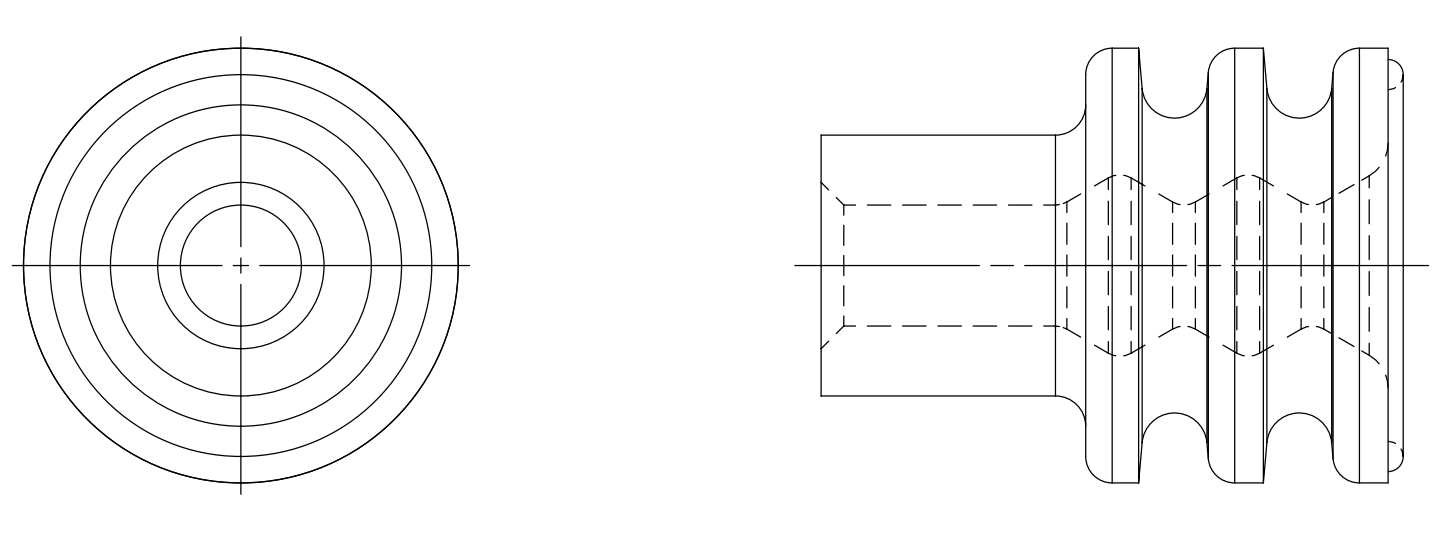

OPTIONAL CONSTRUCTION 2  
THIS IS THE PREFERRED CONSTRUCTION FOR NEW TOOL BUILDS  
(ANTI-STICK RING)

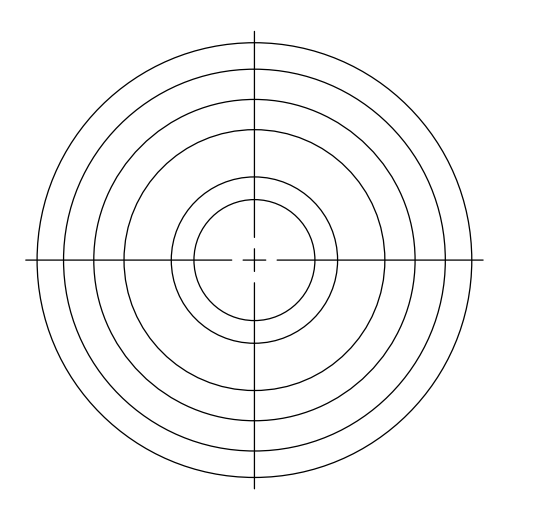
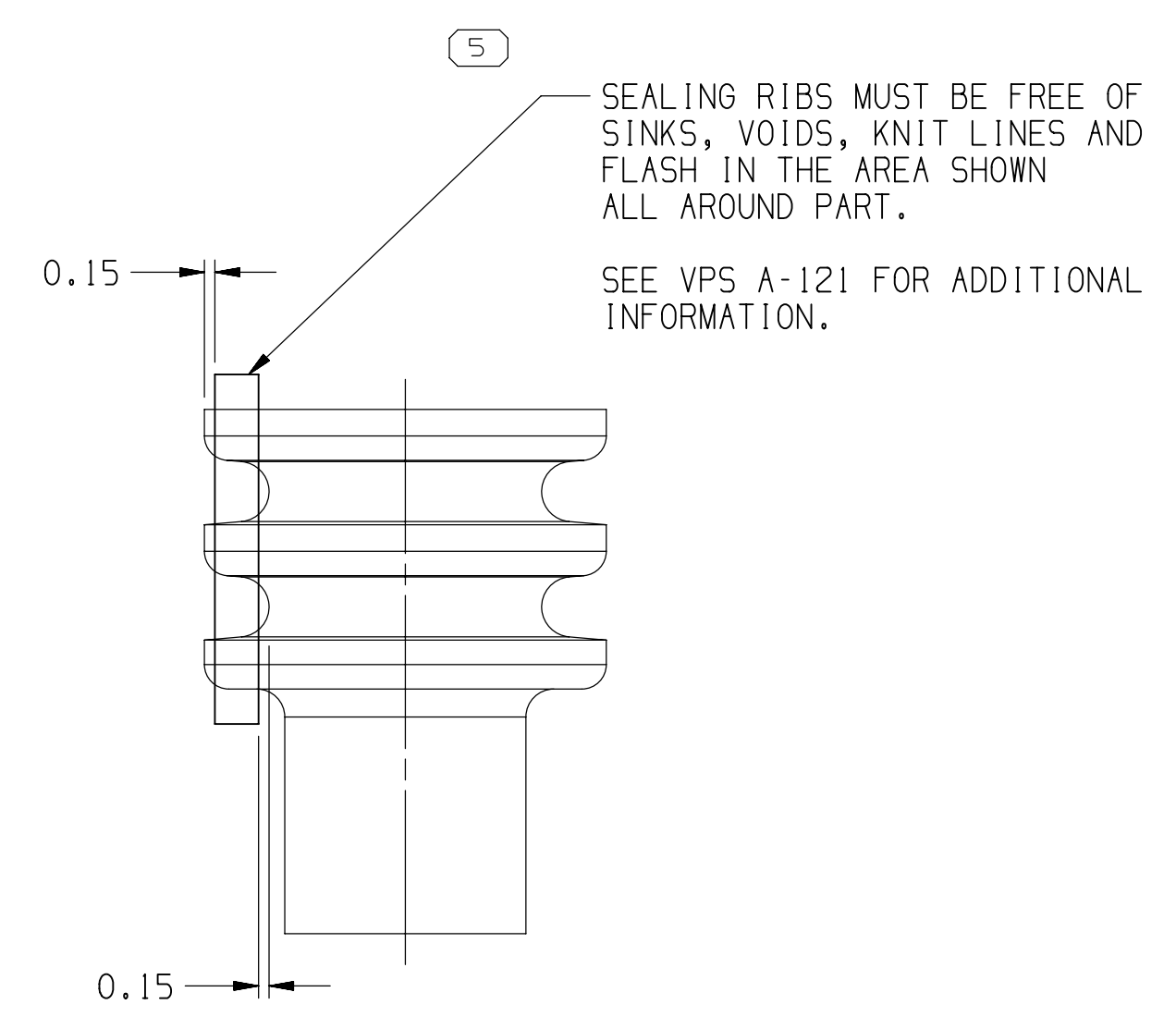

TYPE 401

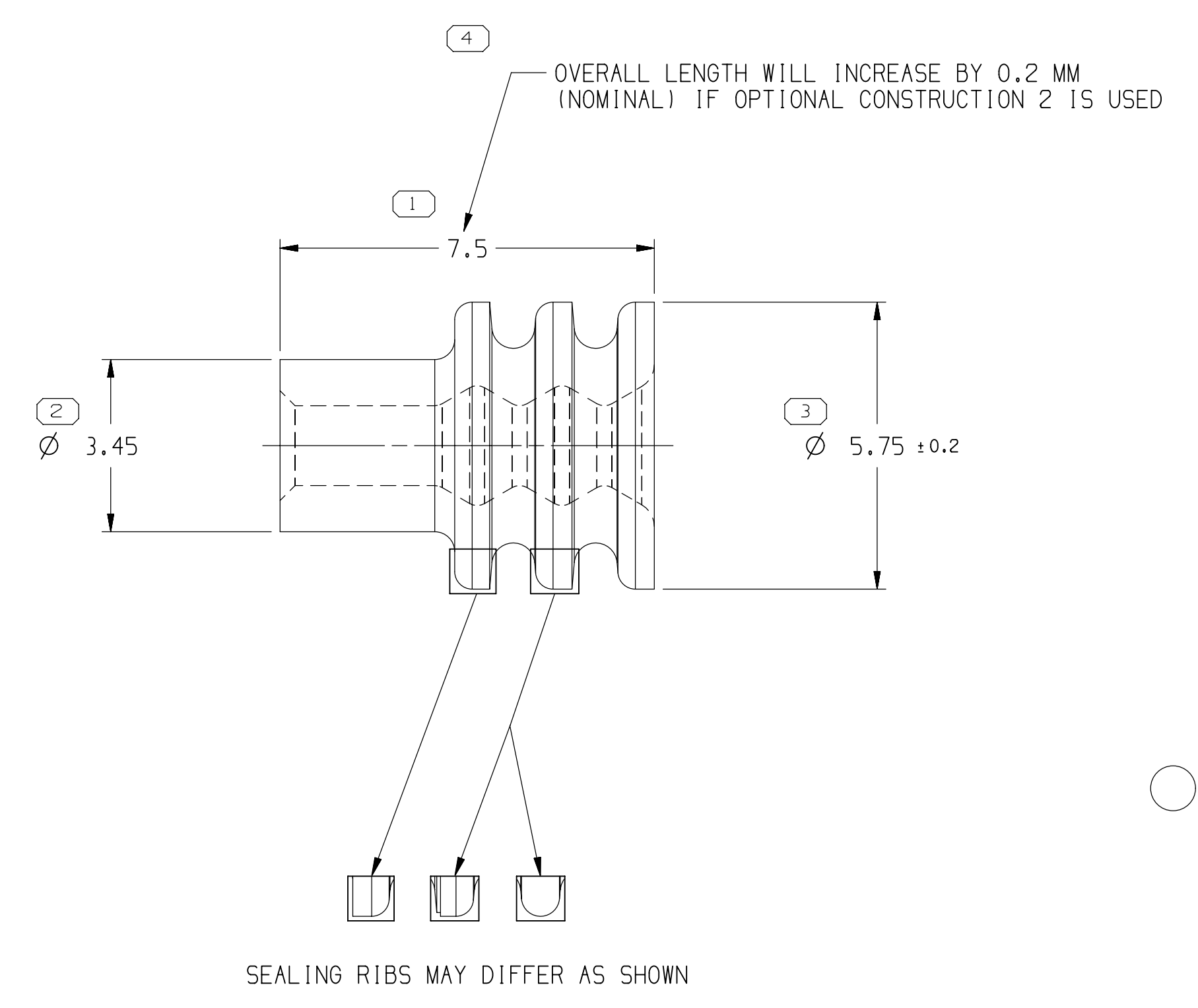

TYPE 402  
SAME AS TYPE 401  
EXCEPT AS SHOWN

SYMBOL DEFINITION		MISSING SYMBOLS	
A DIMENSION WITHOUT AN INSPECTION REPORT SYMBOL DOES NOT REQUIRE INSPECTION. IT MAY BE CONTROLLED ON THE INDIVIDUAL COMPONENT DRAWING.	TOTAL NO OF INSPECTIONS REQUIRED	NO MISSING SYMBOL NUMBER	
	5		
	LAST NO. USED		
	5		

DWG STATUS		ZONE		REVISION HISTORY		AUTH		DR		APVD	
DATE	STG	REV	N/P	CHG							
03DEC99	R	001	-	-	ALL PARTS - REDRAWN TO PD	990009	EOV	CMP	RRH		
03DEC99	R	002	-	-	15324973-76 & 15324979 - RELEASED	990005	EOV	CMP	RRH		
17MY00	R	003	-	-	15393249 - RELEASED	000005	MAC	MAC	MM		
07NOV00	R	004	-	-	15324973-76 & 15324979 - REVISED	202978	JLZ	EAR	JR		
07NOV00	R	005	-	-	15393249 - REVISED MYLAR & CABLE SEAL ASM COLUMN	204413	EAR	EAR	JR		
19JAO1	R	006	-	-	UPDATED PDM ATTRIBUTES	205150	JLZ	JLZ	JR		
09JAO1	R	007	-	-	15393249 - PM009216 WAS PM002196 AND "Ø" DIM WAS 5.75 +/- 0.15	205774	MAC	MAC	TP		
29MR01	R	008	-	-	15393249 - MAT'L SPEC WAS PM009216	207669	FHM	FHM	TL		
06NOV01	R	009	-	-	12048086 - UPDATED PDM ATTRIBUTES	215063	MRL	MRL	DLB		
10FEO3	R	10	-	-	15324974 AND 15324976 - UPDATED PDM ATTRIBUTES	236300	BRB	BRB	MLP		
05AP04	R	11	-	-	12052925, 12052924, 15393249, 15324979, 15324976, 15324975, 15324973, 12186769, 12129926, 12110213, 12089678, 12089441, 12084193, 12048087, AND 12048086 - UPDATED MAT'L SPECS, REMOVED MAT'L SPEC NOTES, NOTE 9 WAS 10 AND REMOVED OLD NOTE 9, REMOVED "Ø" DIM 2 PLCS AND "A" COLUMN FROM CHART, ADDED COLOR COLUMN TO CHART	251238	BRB	BRB	MR		
19NOV04	R	12	-	-	REVISED CHART	261378	MLM	MLM	MR		
23FEO5	R	13	-	-	12048086, 12048087, 12084193, 12089678, 12110213, 12186769, 12052924, 12052925, 12124669, 12089442 AND 12186770 ADDED RESTRICTED STATUS; 15324973-4976 AND 15324979 MAT'L SPEC WAS M3466; ADDED NOTES COLUMN TO CHART; NOTE 7 WAS 9, NOTE 8 WAS 7 AND NOTE 9 WAS 8; REMOVED DIM "C" FROM TYPE 402 VIEW	265239	RRH	RRH	MR		
10JNO5	R	14	-	-	REVISED GRAPHICS	269180	BPS	JVM	MFR		
17FEO6	R	15	-	-	REVISED CHART	277502	MM	MM	MR		
03MR06	R	16	-	-	15324973-76 & 15324979 - MAT'L SPEC WAS M3469	277946	HCG	JVM	MR		
17AUG06	R	17	-	-	15324975 - OBSOLETE	273517	CCV	AUG	MR		
03OC06	R	18	-	-	ALL ACTIVE PARTS - ADDED SEALING RIBS VIEWS, OVERALL LENGTH LABEL, SEALING RIBS LABEL, ANTI-STICK RING OPTIONAL CONSTRUCTION 1 & 2 VIEWS AND DIMS (2 PLCS); 12084193 & 12124669 - REMOVED RESTRICTED; OPTIONAL CONSTRUCTION VIEWS, CONSTRUCTION LINE VIEWS, TYPES 404, 405 & 406 VIEWS AND COLUMNS C, F & G FROM CHART; DIM Ø 3.45 WAS Ø C, DIM Ø 5.75 Ø 0.2 WAS Ø 6 & DIM 7.5 WAS F, CABLE OD RANGE 1.2 - 1.7 WAS 1.29 - 1.7 AND EQUIVALENT CABLE SEAL COLUMN; 15324973-74, 15324976 & 15324979 - MAT'L SPEC M3469 WAS M3466 & ADDED ALTERNATE MAT'L SPEC M3466XXX	285225	UBD	FRG	MFR		
11OC07	R	19	-	-	ALL ACTIVE PARTS - ADDED NOTE 10, USAGE COLUMN AND CHAMFER TO TYPES 401, REVISED TYPE 403 TO 401	402596	RRH	RRH	MFR		
30SE08	R	20	-	-	13713910 & 13713911 - RELEASED	406278	RRR	AGN	RRR		
01MY09	R	21	-	-	ALL ACTIVE PARTS - UPDATED MAT'L SPEC TO GENERIC CALLOUT, REMOVED ALTERNATE MAT'L SPEC COLUMN FROM CHART; 12186769 - REMOVED NOTE FROM CHART AND 13713910 & 13713911 - OBSOLETE	407894	RTV	AUG	MFR		
03JNO9	R	22	-	-	13766444 - RELEASED	408127	ECB	AUG	JGS		
24JL09	R	23	-	-	ALL PARTS - ADDED VOLUME COLUMN AND REMOVED COLOR COLUMN	408462	ECB	AUG	MFR		
30OC09	R	24	-	-	12084193 - UPDATED PDM ATTRIBUTES	409370	JAR	JAR	MFR		
15MY10	R	25	-	-	UPDATED PDM ATTRIBUTES	410847	MAL	MAL	JFB		
15JNO10	R	26	-	-	12052924-25, 12089442, 12124669, 12146011, 12186770 & 13713910 - MOVED TO SHT 6; 12048086-87 & 12089678 - OBSOLETE AND ADDED "REPLACED BY" COLUMN ON CHART	411067	AGM	JAA	MFR		
12JAL11	R	27	-	-	15324973 - UPDATED PDM ATTRIBUTES	413028	AHY	DMC	JEM		
13SE19	R	28	-	-	12089678 - REINSTATED AND ADDED RESTRICTED USAGE COLUMN	444511	JGO	JAA	JAF		
05OC21	R	29	-	-	ALL ACTIVE PARTS - REVISED "TO IMPROVE SEAL" NOTE	555461	BDH	JAA	ACR		

- NOTES
- UNLESS OTHERWISE SPECIFIED AND/OR INDICATED: DIMENSIONS ARE TO FACE OF VIEW SHOWN AND AUTOMATICALLY ROUNDED BY COMPUTER FOR INSPECTION (SEE MATH MODEL FOR PRECISE DIMENSIONS). FOR ALL OTHER DIMENSIONS NOT SHOWN BUT REQUIRED FOR TOOL BUILD, SEE MATH MODEL FOR PRECISE TOOL PATH DATA.
  - SEALING RIBS ARE IDENTICAL, EXCEPT AS SHOWN.
  - PARTS NOT MADE ON FLASHLESS MOLDS MUST BE DEFLASHED, WASHED AND DRIED AFTER MOLDING. WASHING SHOULD OCCUR WITHIN 12 HOURS AFTER MOLDING.
  - PARTS ARE TO BE PACKAGED IN SEALED PLASTIC BAGS. GROSS WEIGHT INCLUDING CARTON IS NOT TO EXCEED 34 POUNDS.
  - PARTS MUST BE MADE FROM VIRGIN MATERIAL ONLY.
  - TO IMPROVE SEAL PROCESSING ON SLIPPERY OR SMOOTH CABLE INSULATION, THE APPLICATION ENGINEER MAY SPECIFY THE NEXT SMALLER SEAL SIZE P/N IN PLACE OF THE INDICATED SEAL FOR THE "CABLE O.D." LISTED IN THE CHART.
  - DESIGNED FOR 0.8 MM<sup>2</sup> SOLID CORE DRAIN WIRE Ø 1.002 ± 0.007
  - PARTS MADE OF FLUOROSILICONE MUST BE POST-CURED FOR 4 HRS AT 400° F.
  - THIS PRODUCT IS NOT CATEGORIZED AS AN APPEARANCE ITEM, MINOR IMPERFECTIONS INCLUDING, BUT NOT LIMITED TO, FLOW MARKS, COLOR BLEMISHES, GATE VESTIGE, AND SOFT FLASH THAT DO NOT AFFECT THE FIT, FORM, OR FUNCTION OF THE PART ARE PERMISSIBLE PER EXNP-4-3-CS-01-EN.
  - P/N 13713911 MUST BE POST-BAKED FOR 4 HOURS AT 400° F.
  - SEE 12010295 SHEET 6 FOR MYLAR ASSEMBLY INFORMATION.

PART NO	REV	N/P	CABLE SEAL	MATERIAL SPECIFICATION AND COLOR	TYPE	CABLE O.D. ± 0.05 SEE NOTE #6	CAVITY ID	EQUIVALENT CABLE SEAL	NOTES	VOLUME	REPLACED BY	RESTRICTED USAGE
13766444	01	AB		SILICONE METHYL/VINYL GRAY	401	2.15-1.6	5.2	15324979	-	0.099	-	-
13713911	01	AA		SILICONE METHYL/VINYL GREEN	401	2.85-2.03	5.2	-	SEE NOTE 10	0.092	-	-
15393249	01	AK		FLUOROSILICONE METHYL/VINYL GREEN	401	2.15-1.6	5.2	-	SEE NOTE 8	0.099	-	-
15324979	01	AK		SILICONE METHYL/VINYL GRAY	401	2.15-1.6	5.2	12186769	-	0.099	-	-
15324976	01	AK		SILICONE METHYL/VINYL WHITE	401	2.15-1.6	5.2	12089678	-	0.099	-	-
15324975	01	AF		SILICONE METHYL/VINYL OCHER	402	1.009-0.995	5.2	-	SEE NOTE 7	0.109	-	-
15324974	01	AL		SILICONE METHYL/VINYL BLUE	401	1.7-1.29	5.2	12048087	-	0.105	-	-
15324973	01	AL		SILICONE METHYL/VINYL REDDISH BROWN	401	2.85-2.03	5.2	12048086	-	0.092	-	-
12186769	B10	-		SILICONE METHYL/VINYL GRAY	401	2.15-1.6	5.2	15324979	-	0.099	-	-
12129926	BB	-		FLUOROSILICONE METHYL/VINYL ORANGE	401	1.7-1.29	5.2	-	SEE NOTE 8	0.105	-	-
12110213	B9	-		FLUOROCARBON BLUE	401	2.65-1.85	5.2	-	-	0.099	-	-
12089678	A12	-		SILICONE METHYL/VINYL WHITE	401	2.15-1.6	5.2	15324976	-	0.099	-	RESTRICTED
12089441	B	-		SILICONE METHYL/VINYL YELLOW	401	2.15-1.6	5.2	-	-	0.099	-	-
12084193	A9	-		SILICONE METHYL/VINYL TAN	402	1.009-0.995	5.2	-	SEE NOTE 7	0.109	-	-
12048087	O2	AH		SILICONE METHYL/VINYL BLUE	401	1.7-1.29	5.2	15324974	-	0.105	15324974	-
12048086	O2	AG		SILICONE METHYL/VINYL REDDISH BROWN	401	2.85-2.03	5.2	15324973	-	0.092	15324973	-

DIMENSIONAL RANGE (MM)	TOLERANCE UNLESS OTHERWISE SPECIFIED	CHART ET
FROM 0 TO >0	>0	>30
>0 TO >20	>20	>70
>20 TO >30	>30	>100
>30 TO >50	>50	>150
>50 TO >100	>100	>200
>100 TO >200	>200	>250
>200 TO >300	>300	>300
>300 TO >400	>400	>400

THIRD ANGLE PROJECTION	DO NOT SCALE	USE MATH DATA

**APTIV**  
CONNECTION SYSTEMS  
WARREN, OH  
COPYRIGHT 1989 APTIV, ALL RIGHTS RESERVED.  
THIS DRAWING IS THE PROPERTY OF APTIV AND CONTAINS APTIV CONFIDENTIAL INFORMATION. THE REPRODUCTION, DISTRIBUTION AND UTILIZATION OF THIS DOCUMENT OR ITS RELATED CAD DATA, AS WELL AS COMMUNICATION OF ANY CONTENT TO OTHERS, WITHOUT EXPRESS AUTHORIZATION, IS PROHIBITED.

DATE: 12-08-21  
TIME: 08:56:32

DRAWING NAME: TAXI SEAL CBL IW M/P  
DRAWING NUMBER: 12010295  
SIZE: A0  
SCALE: 10:1  
FRAME NO: 1  
SHEET NO: 4  
STG: 1  
REV: 29