

PART CHARACTERISTICS		
NUMBER OF POSITION	ASSEMBLY ITEM NUMBER	MATERIAL
02	43025-0200	"B"
04	43025-0400	
06	43025-0600	
08	43025-0800	
10	43025-1000	
12	43025-1200	
14	43025-1400	"B"
16	43025-1600	"A"
18	43025-1800	"B"
20	43025-2000	
22	43025-2200	
24	43025-2400	"A"

CKT. NO.	DIM. "A" +0.014 -0.010 +0.35 -0.25	DIM. "B"
2	.152/(3.86)	N/A
4	.270/(6.85)	.118/(3.00)
6	.388/(9.85)	.236/(6.00)
8	.506/(12.85)	.354/(9.00)
10	.624/(15.85)	.472/(12.00)
12	.742/(18.85)	.591/(15.00)
14	.860/(21.85)	.709/(18.00)
16	.978/(24.85)	.827/(21.00)
18	1.096/(27.85)	.945/(24.00)
20	1.215/(30.85)	1.063/(27.00)
22	1.333/(33.85)	1.181/(30.00)
24	1.451/(36.85)	1.299/(33.00)

NOTES:

- HOUSING MATERIAL:
"A" - UNFILLED POLYESTER, RATED U.L. 94V-0, COLOR IS BLACK.
"B" - UNFILLED NYLON, RATED U.L. 94V-0, LOW HALOGEN, COLOR IS BLACK.
- FINISH: N/A
- PRODUCT SPECIFICATION: PS-43045
- PACKAGING SPECIFICATION: PK-43025-001
- THIS RECEPTACLE MATES WITH 43020, 43045.
- THIS RECEPTACLE TO BE USED WITH MOLEX FEMALE TERMINAL SERIES 43030 OR 46235. SEE SECTION "A"- "A" FOR TERMINAL ORIENTATION IN HOUSING.
- FOR OVERMOLDING PARAMETERS SEE APPLICATION SPECIFICATION 430250000-AS.
- TOP PULL TABS ARE NOT AVAILABLE ON 2 AND 4 CIRCUIT PARTS.
- MOLEX RECOMMENDS THE USE OF MICRO-FIT TEST PLUG, SERIES NO. 44242-**** WHENEVER TESTING IS PERFORMED. TEST PLUGS MUST NOT BE USED FOR MAKE OR BREAK UNDER LOAD. MOLEX DOES NOT RECOMMEND USING STANDARD MATING COMPONENTS FOR HARNESS TESTING PURPOSES.
- SOME HOUSINGS MAY HAVE A SMALL GATE BLEMISH NEAR THE GATE THAT DOES NOT AFFECT FUNCTIONALITY.
- HOUSINGS HAVE EITHER AN IDENTIFIER RIB OR ENGRAVED "1" SYMBOL TO INDICATE CIRCUIT #1. IDENTIFIER TYPE IS TOOL DEPENDENT AND NOT SELECTABLE.
- DIMENSION 'A' MEASURED AT DATUM **-A-**
- THIS PART CONFORMS TO CLASS 'B' REQUIREMENTS OF COSMETIC SPECIFICATION PS-45499-002.
- TEXT ON PART IS FOR REFERENCE ONLY. TEXT AND TEXT LOCATION MAY VARY DEPENDING ON PART NUMBER AND/OR TOOL.

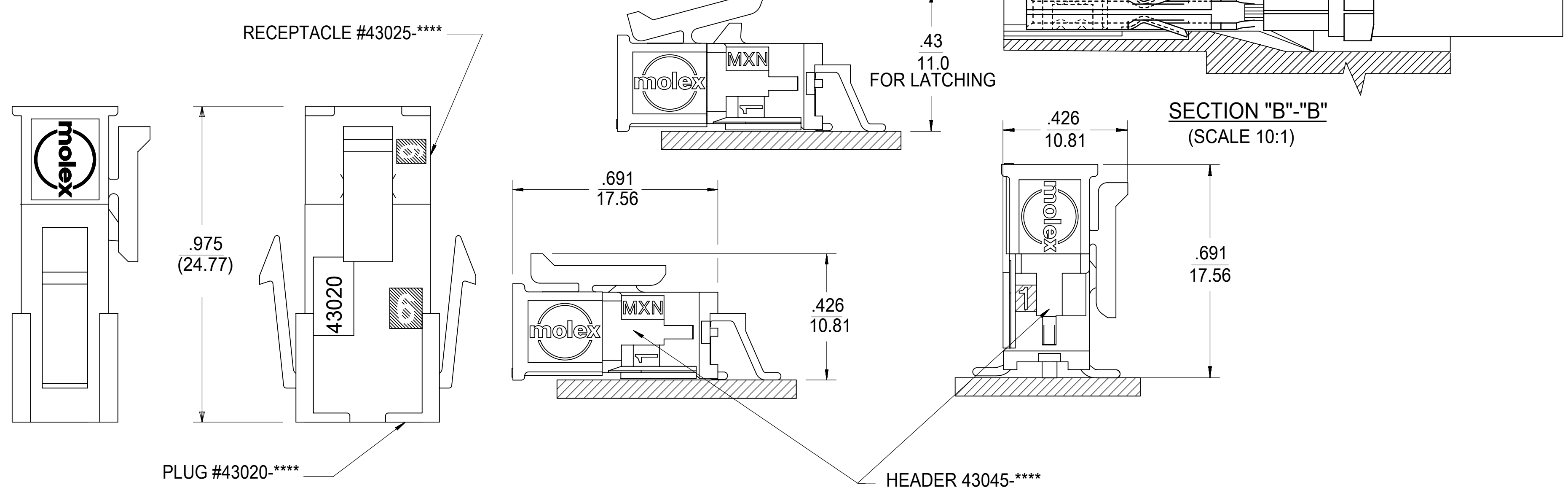

MATED MICRO-FIT CONNECTOR

THIS DRAWING REPLACES DRAWING SDA-43025-****

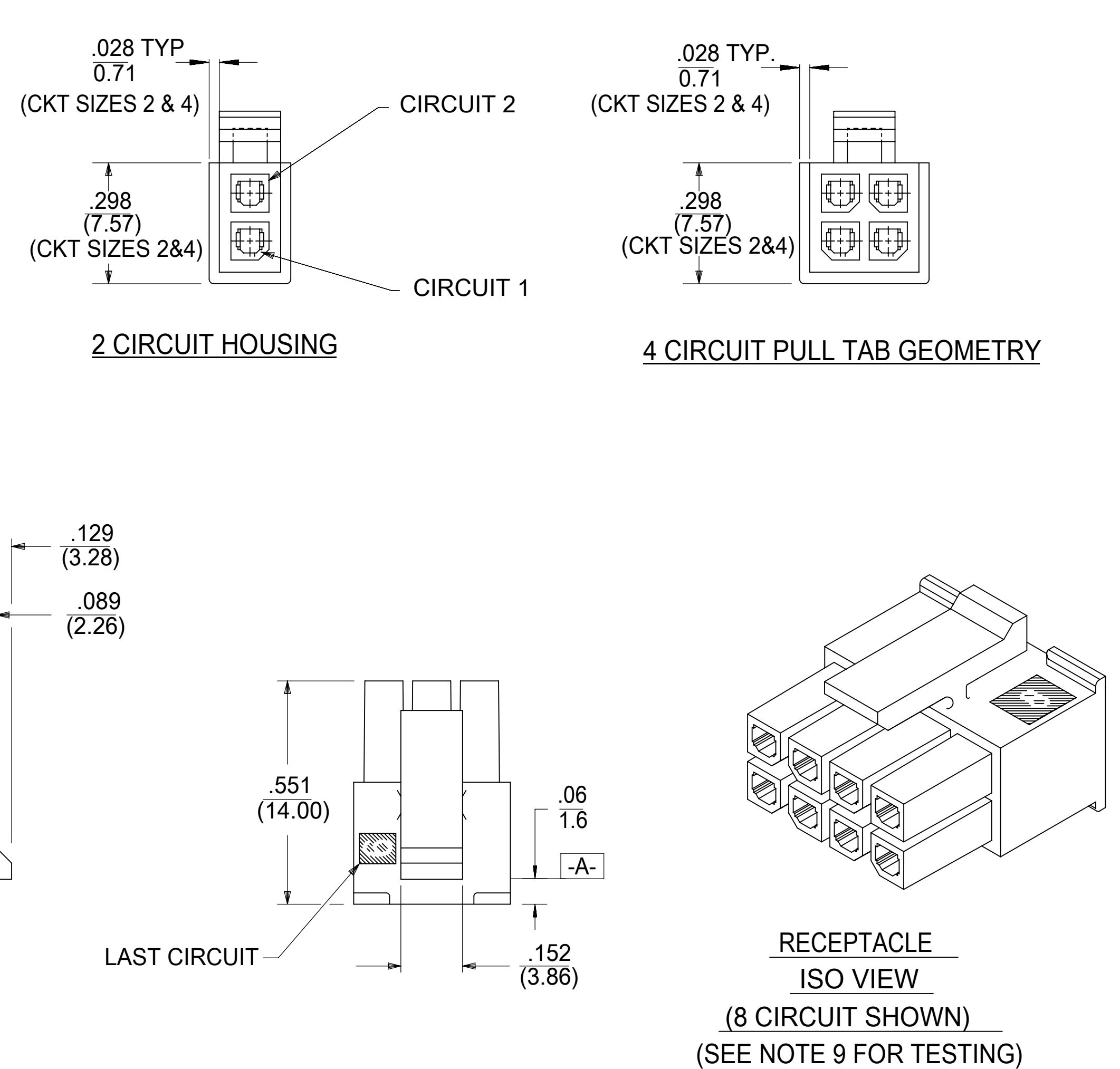
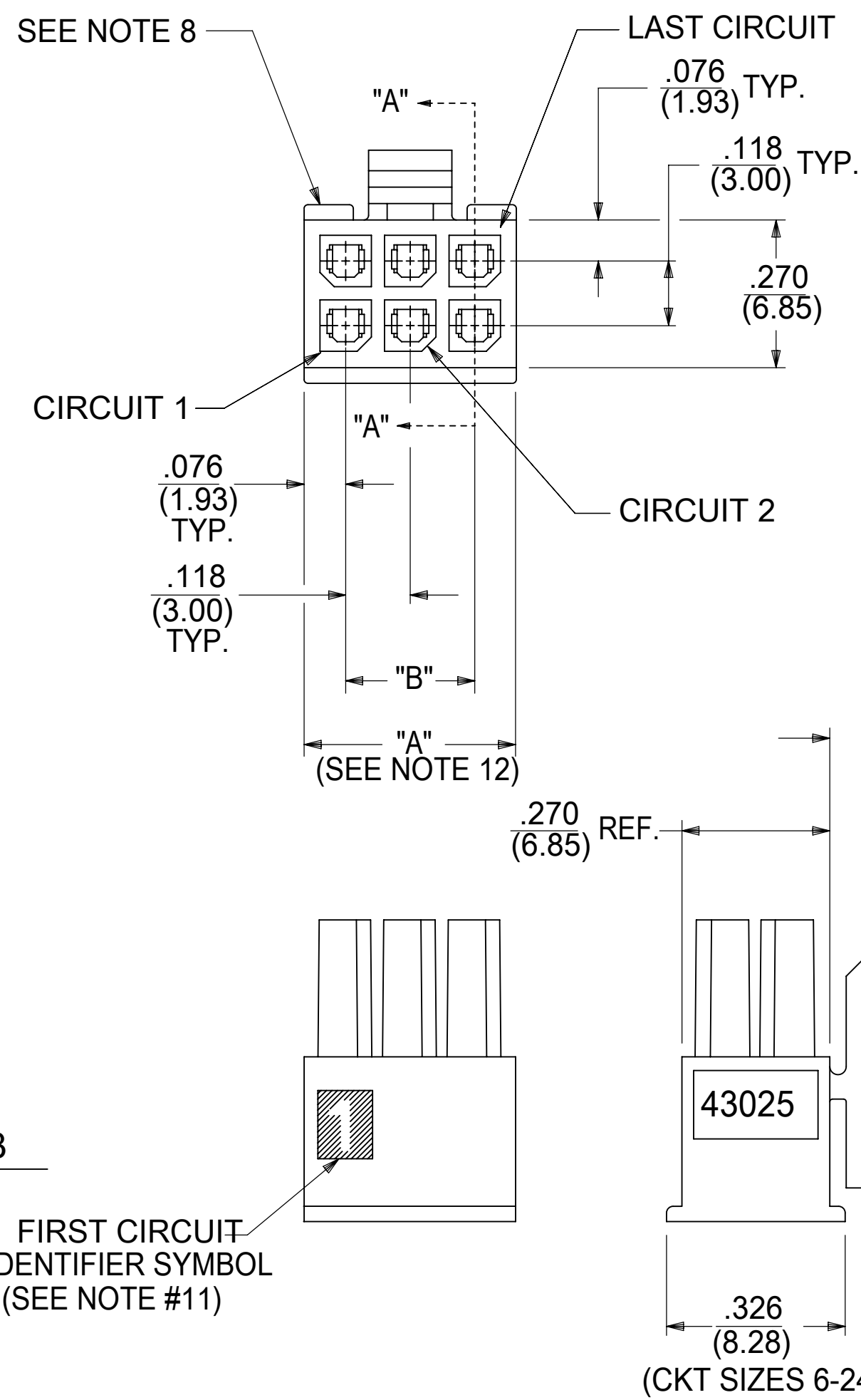

SYMBOLS										THIS DRAWING CONTAINS INFORMATION THAT IS PROPRIETARY TO MOLEX ELECTRONIC TECHNOLOGIES, LLC AND SHOULD NOT BE USED WITHOUT WRITTEN PERMISSION														
DIMENSION UNITS					SCALE					CURRENT REV DESC: INITIAL RELEASE														
= 0					IN/MM NTS					<p>molex</p> <p>MICRO-FIT (3.0) 2-24 CIRCUIT RECEPTACLE</p> <p>PRODUCT CUSTOMER DRAWING</p> <p>DOCUMENT NUMBER: 430250000-SD DOC TYPE: PSD DOC PART: 000 REVISION: A</p> <p>MATERIAL NUMBER: SEE TABLE CUSTOMER: SHEET NUMBER: 1 OF 1</p>														
GENERAL TOLERANCES (UNLESS SPECIFIED)																								
4 PLACES ±					±															EC NO: 168740				
3 PLACES ±					± 0.01															DRWN: AZAHIROVIC 2018/03/06				
2 PLACES ±					0.25 ± 0.014															CHK'D: SSOUSEK 2018/06/01				
1 PLACE ±					0.35 ±					APPR: FSMITH 2018/06/01														
0 PLACES ±					±					INITIAL REVISION:														
ANGULAR TOL ± 0.5°					±					DRWN: A.F.G. 1993/01/14														
DRAFT WHERE APPLICABLE MUST REMAIN WITHIN DIMENSIONS					THIRD ANGLE PROJECTION					APPR: FSMITH 2016/05/02														
D-DRAWING					SERIES					43025														

DOCUMENT STATUS	P1	RELEASE DATE	2018/06/01	21:26:12
-----------------	----	--------------	------------	----------